

Reliable, maintenance-free waste liquid level measurement

- Suitable for all water-based liquid waste
- Non-stick coating
- Continuous measurement
- Compensates for irregular shaped tanks
- No holes to block
- No moving components



SPECIFICATION

Primary Output Accuracy	+/-10% FSD @ 20°C
Thermal Drift	<10% FSD over full temperature range

ELECTRICAL

Supply voltage	+6 to +32V DC
Over Voltage Protection	50V DC
Supply Current	<40mA
Reverse Polarity Protection	-32V DC
Resolution	12 bit (4096 points over measurement range)
Output Update Rate	100Hz (Resistive) 10Hz (0-10V & 4-20mA)
Configuration Interface	Accessible via local micro USB port
Primary (Volumetric) Output	Configurable through user software using tank profiling or file upload
Secondary (Switch) Output	Open collector output 50V / 0.5A max switch to ground (V-)
Secondary Output Hysteresis	Configurable through user software

RESISTIVE OUTPUT

Primary Outputs	10-180Ω or 240-33Ω selectable through user software
Standard Range	Datum A to Datum B (see Dimensions)
Primary Output Maximum Range	10-1000Ω or 1000-10Ω Configurable through user software

ORDERING

Length Range (mm): 1 = 250, 350, 450 2 = 600, 800, 1000 3 = Custom 50 to 2000 (MOQ)	Output Type: K = voltage L = current M = resistive	Mounting thread: A = 1.25" BSP
Exact Length (mm):		
7014 - 00 - <input type="text"/> <input type="text"/> <input type="text"/> - <input type="text"/> <input type="text"/> <input type="text"/> <input type="text"/>		

ENVIRONMENTAL

Ingress Protection	IP66 / IP68 / IP69k to EN60529
Operating Temperature	-40°C to +85°C (without cable)
Humidity	93% RH at 40°C EN60945
EMC	EN60945 (Marine) EN61000-6-3 (Light Industrial) EN61000-6-2 (Heavy Industrial) EN61326-2-1 (Measurement Control)
Corrosion Resistance	Marine grade stainless steel 316 construction
Differential Pressure	10 Bar
Absolute Pressure	5 Bar
Compatible Media	All water based liquid waste
Venting	Use in vented tanks only

MECHANICAL

Wetted Materials	Stainless steel 316, FEP, EPDM
Probe Length	Range 1: 250, 350 or 450 mm Range 2: 600, 800 or 1000 mm Range 3: Custom 50 to 2000mm (MOQ applies)
Tank Seal Options	EPDM O-ring or Klingsil panel gasket
Cable	Marine standard screened cable (temperature rating -40°C to +75°C)
Cable Pull	3 axis, 50N

VOLTAGE OUTPUT

Primary Output Standard Range	0.25 - 4.75V DC*
Primary Output Maximum Range	0.25 - 10V DC* Configurable through user software

* Supply voltage to be at least 0.5 V greater than the required output voltage

CURRENT OUTPUT

Primary Output Standard Range	4-20mA Range is Datum A to Datum B (see Dimensions)
Primary Output Maximum Range	4-20mA Configurable through user software

➤ More information at www.sensovant.com

E comercial@sensovant.com

T +34 968 162 005





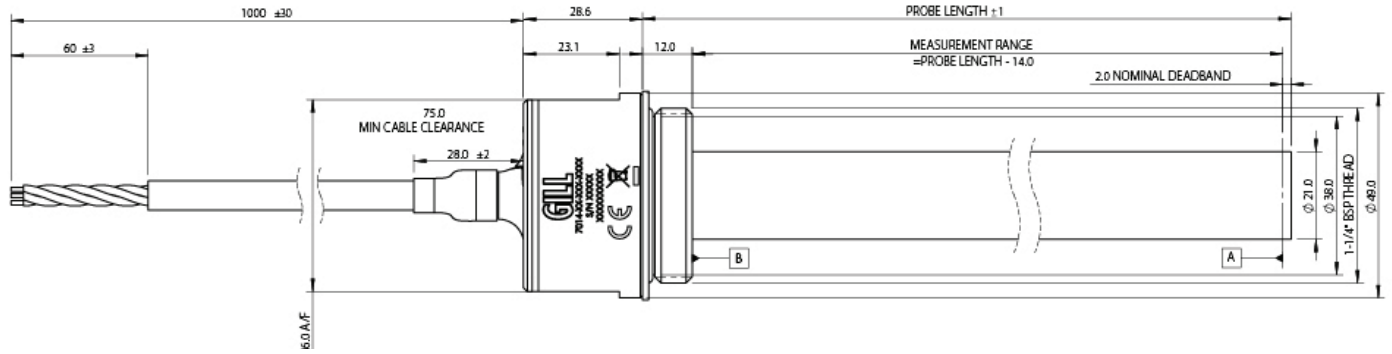

GILL

Sensors & Controls

DIMENSIONS



WIRING DESIGNATION

	Black	-V (Ground)
	Red	+V
	Blue	Switch Output
	Silver	Bare drain wire
	White	Output