

Developer's Guide for

HCT01 Humidity and Temperature Sensors

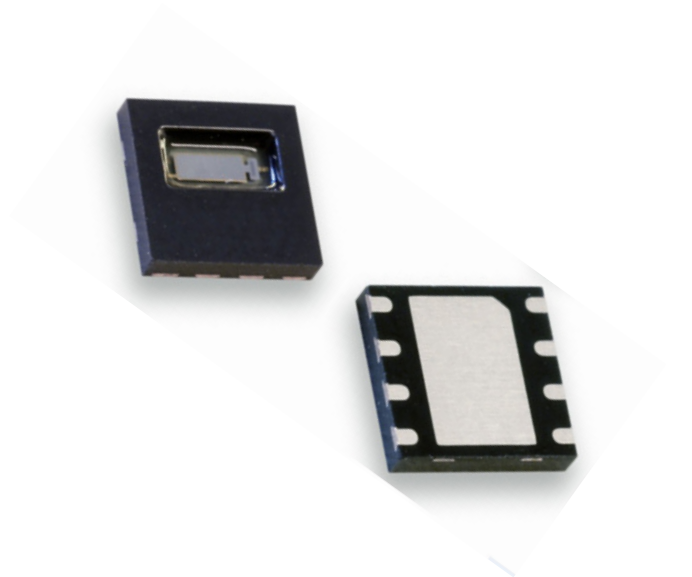

Table of content:

1	Driving circuitry for HCT01	4
2	Pre-adjusted HCT01 with an initial accurate circuitry with frequency output	6
2.1	Schematic circuit diagram	6
2.1.1	Bill of Material.....	6
2.1.2	Correlation between sensor capacity and period.....	7
3	RH measurement with pre-adjusted HCT01 and microcontroller based, initially accurate circuitry	8
3.1	Schematic circuit diagram	8
3.1.1	Bill of Material.....	9
4	Hints for the development engineer	11
5	Contact information	12
6	Revision history	12

1 Driving circuitry for HCT01

HCT01 is a capacitive, thin-film sensor for relative humidity (RH) in a robust SMD enclosure. The enclosure can accommodate an optional high precision temperature (T) sensor – a prerequisite for precisely calculating dew point.

The enclosure provides optimal mechanical sensor protection and can be used with a standard reflow process. The E+E proprietary coating protects the active surface of the RH sensor against dust, salt and other corrosive or low impedance deposits.

The choice of HCT01 sensor type

HCT01 is available as pre-adjusted (**HCT01-02** and **HCT01-03**) or unadjusted **HCT01-00** RH sensor, each of these with or without integrated T sensor. The choice is based on accuracy requirements, on the availability of humidity calibration benches, on the available or intended driving electronics and on cost/performance considerations and it is illustrated in Figure 1. Additionally, Figure 1 gives an overview on the accuracy which can be achieved by various combinations of HCT01 circuitry.

- Using an unadjusted RH sensor (**HCT01-00**) implies humidity calibration for the device built with it. The accuracy achieved depends mainly on the overall uncertainty of the calibration process.
- A pre-adjusted RH sensor (**HCT01-02/03**) eliminates the need for humidity calibration. The accuracy of the final device rests solely on the spread of the initial accurate electronics employed.

The choice of driving circuitry

The driving circuitry for HCT01 can be realized with an oscillator as “capacity to frequency converter” or with a microcontroller.

Features of the capacity to frequency converter:

Cost efficient solution – material costs approx. 0,25 € (using an existing oscillator)
Accuracy $\pm 0,8$ % rH
Extremely short measuring time possible to save power and prevent self heating
Frequency (period) output

Features of the microcontroller based circuitry:

Cost efficient solution – material costs approx. 0,05 € (using an existing microcontroller)
Electronic accuracy of ± 1 % rH with reference adjustment
Customer specific, digital output depending on the microcontroller

Choice of HCT01 version and driving circuitry

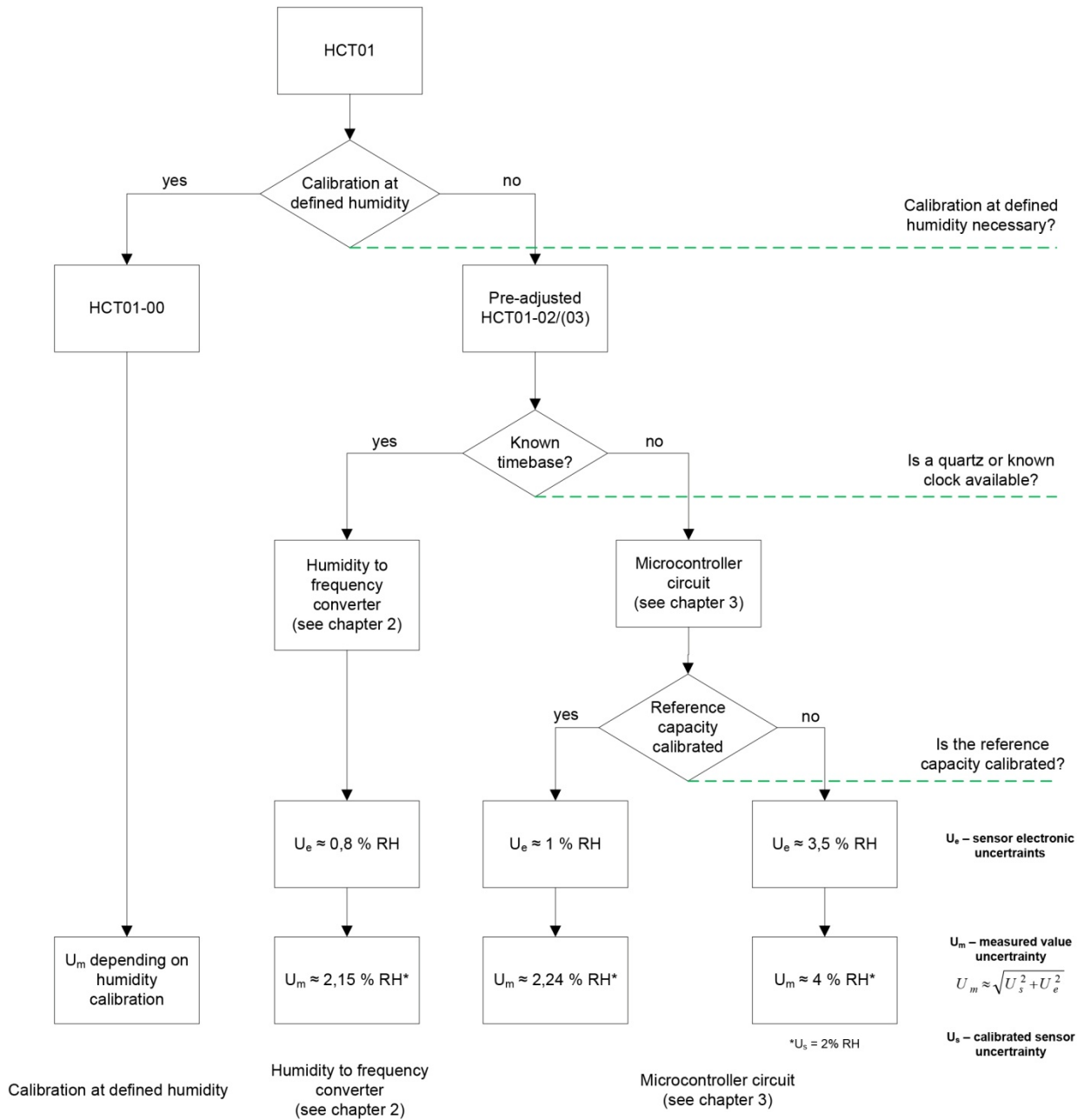

Figure 1: Circuitry options for HCT01

2 Pre-adjusted HCT01 with an initial accurate circuitry with frequency output

The circuitry in Fig. 2 delivers a frequency output signal, where the period of the signal is proportional to the capacity of the RH sensor and consequently with the relative humidity at the sensor. The accurate measurement of the period requires a precise time base such as a quartz crystal.

2.1 Schematic circuit diagram

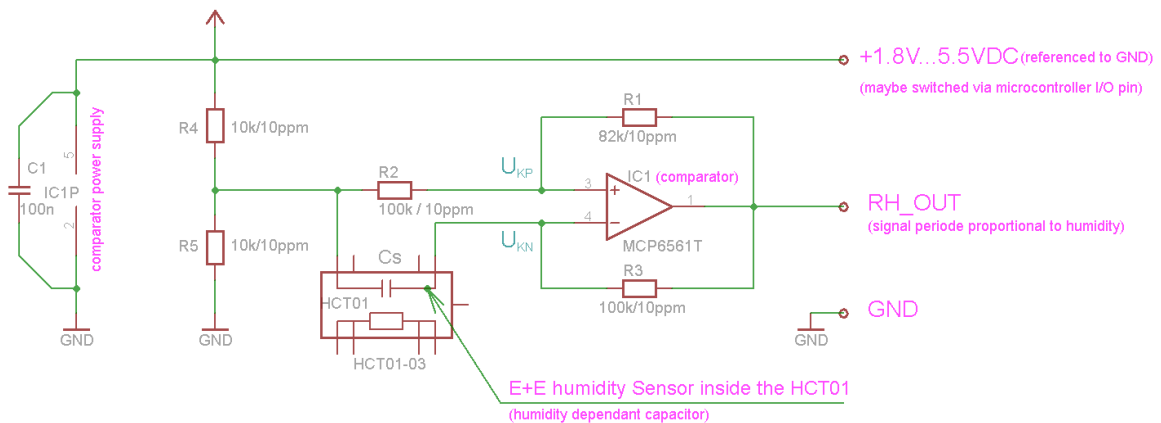

Figure 2: Circuitry with frequency output

2.1.1 Bill of Material

Quantity	Symbol	Device	Dimension	Supplier
1 pc	HCT01	Humidity sensor	HCT01-02 or HCT01-03	E+E Elektronik
1 pc	IC1	Existing comparator	MCP6561T	Microchip
1 pc	C1	Capacitor	100 nF, ceramic	
1 pc	R1	Resistor	82 kΩ	
2 pcs	R2, R3	Resistor	100 kΩ	
2 pcs	R4, R5	Resistor	1 kΩ	

2.1.2 Correlation between sensor capacity and period

- Humidity Sensor HCT01 (approx.): **70 pF @ 0 % rH - 95 pF @ 100 % rH**
- Period at RH_OUT: **70 pF → 19.0 μs cycle duration**
95 pF → 25.4 μs cycle duration

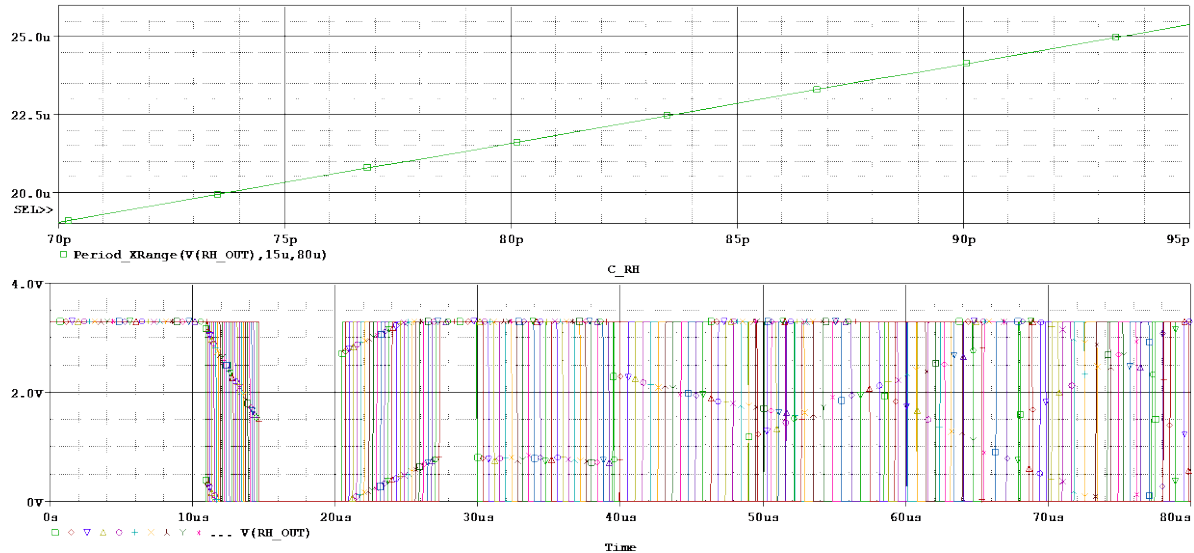

Figure 3: The sensitivity is approx. 0,064 μs/% rH (with a rise of 0.25 pF/% rH)

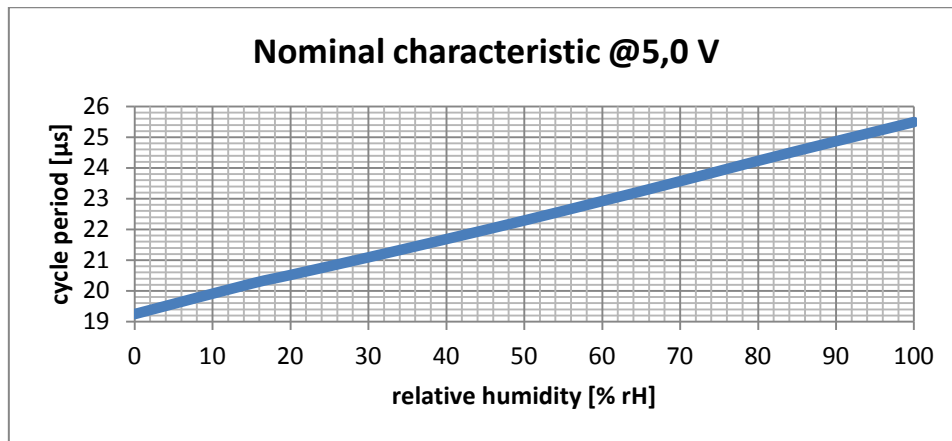

Figure 4: Nominal characteristic of the measuring device with frequency output

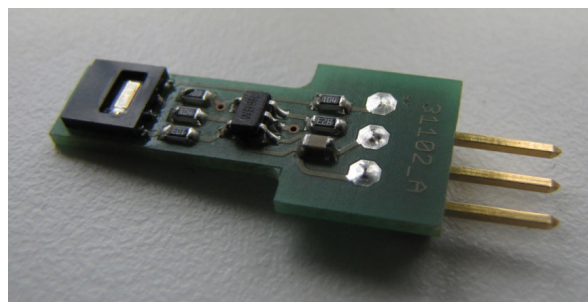

Figure 5: Example of RH & T measuring device with HCT01 and frequency output

3 RH measurement with pre-adjusted HCT01 and microcontroller based, initially accurate circuitry

A measuring device with pre-adjusted HCT01 and with a microcontroller based initially accurate circuitry can achieve an accuracy of $\pm 2,24$ % rH.

A detailed description of the circuitry is available in the E+E patent EP 1 574 847 B1 // US 7,084,644 B2.

3.1 Schematic circuit diagram

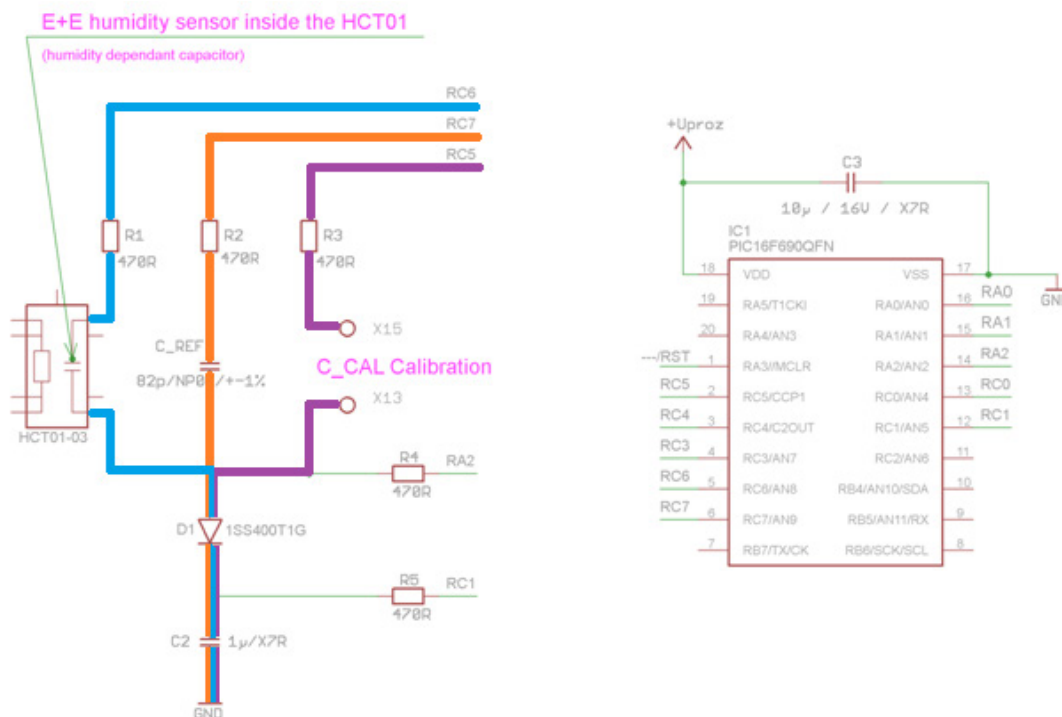

Figure 6: Schematic circuit design¹

There are three possible measurement paths:

- 1.) **Sensor** (capacitance) path with $R1 + HCT01 + D1 + C2 (= C_L)$
- 2.) **Reference** (capacitance) path with $R2 + C_REF + D1 + C2 (= C_L)$
- 3.) **Calibration** (capacitance) path with $R3 + C_CAL + D1 + C2 (= C_L)$

U_L = voltage at $C_L (=C2)$

U_V = Voltage at the voltage divider (reference voltage)

¹ $C_REF = \pm 1\% \rightarrow @82 \text{ pF} = \pm 0.82 \text{ pF} \approx \pm 3.4 \text{ \% rH}$

C_Cal = Capacitance which is used for calibration end testing [no soldering necessary]

All three measurement paths (“sensor” or “reference” or “calibration”) use the same algorithm.

Example: **reference path**:

- 1.) Discharge all capacitors (I/O pins RC1, RC5, RC6, RC7 and RA2 = output LOW)
- 2.) Charge **reference** capacitor and C_L (RC6, RC5, RA2 = input, RC1 = switched to comparator input, RC7 = output HIGH). The charge from the reference capacitor is also transferred in the capacitor $C_2 (=C_L)$ and the voltage in $C_2 (=C_L)$ rises a little bit. C_2 is approx. 10.000 times higher than C_{REF} .
- 3.) Discharging **reference** capacitor (RC6, RC5 = input, RC1 = switched to comparator input, RA2, RC7 = output LOW).
- 4.) Increment the number of charge/discharge events (in this case $N_{C_{Ref}}$).
- 5.) Check if the voltage at the pin RC1 (comparator) reaches the voltage at the voltage divider:
 - no → repeat point 2.) and recharge the **reference**.
 - yes → end of loop and save the numbers of charge/discharge events.
- 6.) Each cycle measures the **reference** path and the **sensor** path and calculates the sensor capacitance from these measurements.

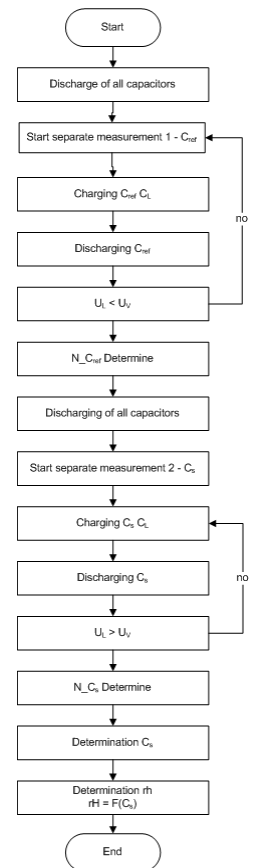

3.1.1 Bill of Material

Quantity	Symbol	Device	Dimension	Supplier
1 pc	HCT01	Humidity sensor	HCT01-02 or HCT01-03	E+E Elektronik
1 pc	D1	Fast Si-Diode	1SS400TiG	
1 pc	C2	Resistor	1 μ F, ceramic / X7R	
1 pc		Existing microcontroller	PIC16F690	Microchip
1 pc	C_REF	Capacitor	82 pF, ceramic / NP0 / CG0	
5 pcs	R1-R5	Resistor	470 Ω	

Requirements for the microcontroller

- 1.) 3 to 4 digital I/O pins, switchable between output and (analog) input
- 2.) Integrated comparator (switchable to digital I/O output), external component also possible
- 3.) Integrated voltage divider (used as reference voltage at comparator), external component also possible

The nominal characteristic of the device (HCT01 sensor together with electronics) can be determined by measurement at various levels of relative humidity.

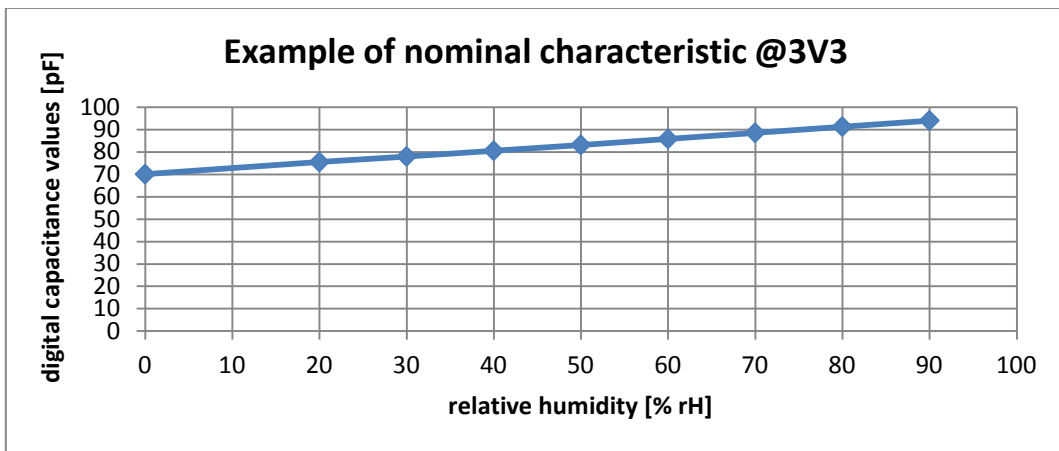

Figure 7: Example of nominal characteristic

The deviation from the reference RH after correcting for PCB influences and hysteresis is shown in Figure 8.

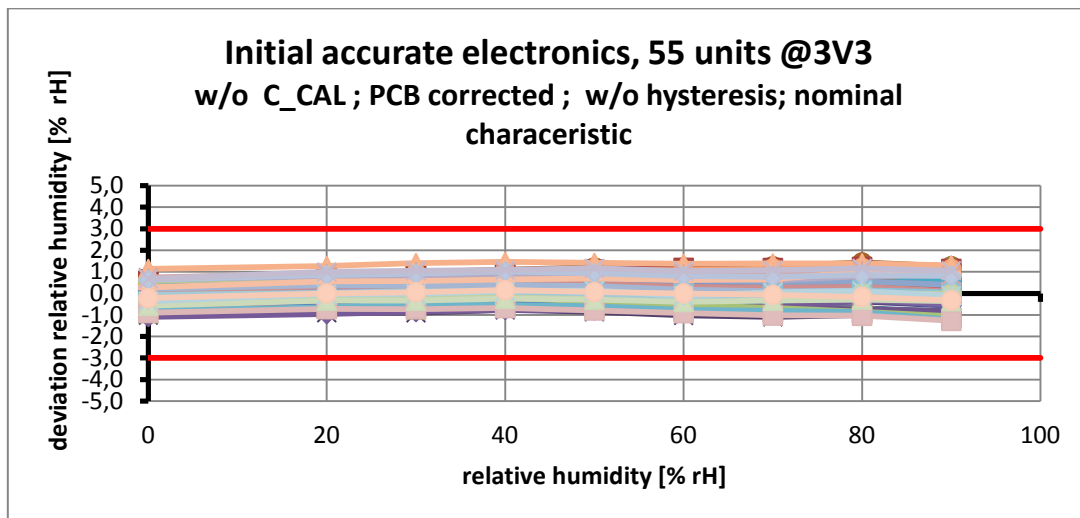

Figure 8: Initial accurate electronics – w/o C_Cal: PCB corrected

For even better overall uncertainty, measure each PCB with a very well defined C_CAL during the electrical test of the PCB. Correct the C_REF based on this measurement, or determine the exact value of C_REF during the PCB in circuit test.

The deviations from reference with C_CAL = 82.79 pF are shown in Figure 9.

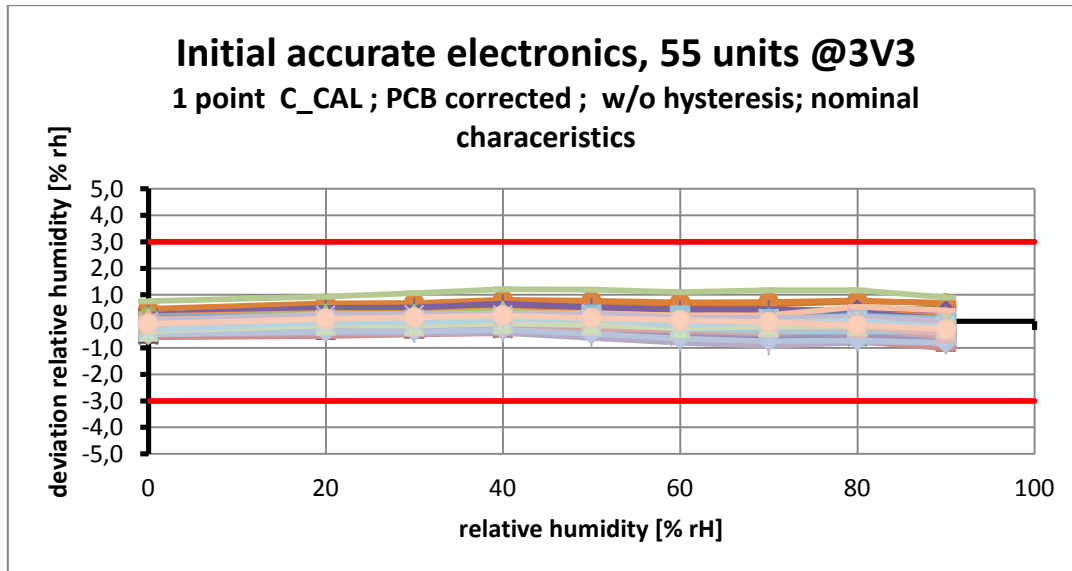

Figure 9: Initial accurate electronics – 1 point C_Cal; PCB corrected

4 Hints for the development engineer

Choose HCT01 version and the driving circuitry according Figure 1 depending on the accuracy and output requirements as well as on existing electronics.

For accurate measurement it is of utmost importance to reduce as far as possible any stray capacitance (and by this also its variation with temperature and humidity) related to the printed circuit board. This might require several test and layout optimizing loops. These imply tests for assessing the impact of the stay capacitance and its variations on the output signal of the device, as follows:

1. Test a sample of relevant size at defined environmental conditions (various combinations of humidity and temperature) for determining the spread of the characteristic of the device including HCT01 sensor.
2. Test a batch of printed circuit boards with a known, accurate capacitor instead of the humidity sensor at defined environmental conditions (various combinations of humidity and temperature) for determining the impact of the board on the output signal.

The electronics design shall be optimized for narrow spread of the characteristic of the entire device and for minimum impact of the electronics layout on the output signal.

5 Contact information

E+E Elektronik Ges.m.b.H.

Langwiesen 7
A-4209 Engerwitzdorf
Austria

Tel.: +43 7235 605 0

Fax.: +43 7235 605 8

E-Mail: info@epluse.com

Homepage: www.epluse.com

Please visit our website to find your local contact.

6 Revision history

Date	Revision number	Changes
November 2011	V_0.1	Initial release
September 2015	V_0.2	Revised version

Copyright© 2014, E+E Elektronik.

Subject to technical changes and misprints

All rights reserved