



—
your partner
in sensor
technology.



User Manual EE300Ex

Humidity and Temperature Transmitter

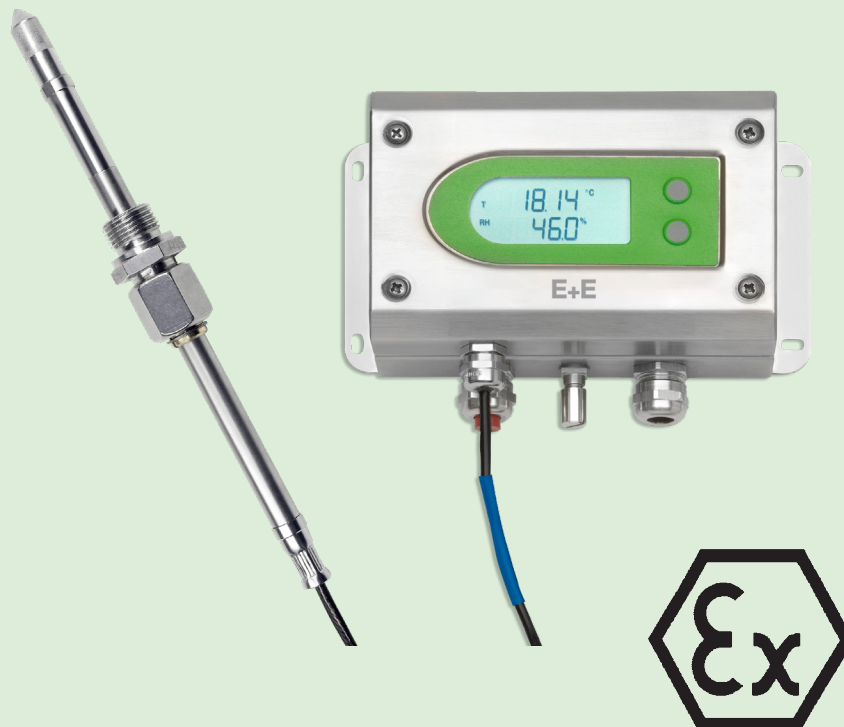

Content

| | | |
|-----------|---|-----------|
| 1 | General Information | 3 |
| 1.1 | Explanation of Warning Notices and Symbols | 3 |
| 1.2 | Safety Instructions | 4 |
| 1.2.1. | General Safety Instructions | 4 |
| 1.2.2. | Intended Use | 4 |
| 1.2.3. | Mounting, Start-up and Operation | 4 |
| 1.3 | Environmental Aspects | 5 |
| 1.4 | ESD Protection | 5 |
| 2 | Scope of Supply | 5 |
| 3 | Product Description | 6 |
| 3.1 | General | 6 |
| 3.2 | Dimensions | 7 |
| 3.2.1. | EE300Ex-M1: Humidity and Temperature Transmitter | 7 |
| 3.2.2. | EE300Ex-M3: Temperature Transmitter | 8 |
| 3.3 | EE300Ex Labelling | 9 |
| 3.4 | Certification | 10 |
| 3.4.1. | EUROPE | 10 |
| 3.4.2. | INTERNATIONAL | 10 |
| 3.4.3. | China (IECEX based) | 11 |
| 3.4.4. | KOREA | 11 |
| 3.4.5. | JAPAN | 12 |
| 4 | Display (Optional) | 13 |
| 5 | Mounting and Installation | 13 |
| 5.1 | General | 13 |
| 5.2 | Enclosure | 14 |
| 5.3 | Assembly in Category 1 (Zone 0 / 20) | 15 |
| 5.4 | Assembly in Categories 2 and 3 (Zone 1, 2 / 21 , 22) | 17 |
| 5.5 | Probe Mounting | 18 |
| 5.5.1. | Probe Feed-through with Cut-in Fitting | 19 |
| 5.5.2. | Mounting Flange | 20 |
| 5.5.3. | Ball Valve and Sliding Fitting | 21 |
| 5.5.4. | The Optional Probe Retraction Tool | 22 |
| 6 | Electrical Connection | 23 |
| 6.1 | General | 23 |
| 6.2 | Terminal Assignment | 24 |
| 6.3 | Grounding and Potential Equalization | 24 |
| 6.4 | Connection Cable | 25 |
| 6.5 | Calculation of the Maximum Cable Length | 26 |
| 6.6 | Selecting a Suitable Intrinsically Safe Supply Unit for ATEX Zone Concept | 27 |
| 6.7 | Configuration Adapter | 28 |
| 6.8 | Calibration of the Current Loop | 28 |
| 7 | Maintenance and Service | 29 |
| 7.1 | Filter Cap Exchange | 29 |
| 7.2 | Cleaning the EE300Ex Transmitter | 29 |
| 7.2.1. | Cleaning the Enclosure | 29 |
| 7.2.2. | Cleaning the Probe | 29 |
| 7.3 | Configuration, Adjustment and Calibration | 29 |
| 7.4 | Error Messages on Display | 29 |
| 7.5 | Repairs | 30 |
| 8 | Accessories | 30 |
| 8.1 | EE300Ex-M1 Humidity and Temperature Transmitter | 30 |
| 8.2 | EE300Ex-M3 Temperature Transmitter | 30 |
| 9 | Technical Data | 31 |
| 9.1 | EE300Ex-M1 Humidity and Temperature Transmitter | 31 |
| 9.2 | EE300Ex-M3 Temperature Transmitter | 33 |
| 9.3 | Accuracy of E+E Humidity and Temperature Transmitters | 34 |
| 10 | Conformity | 34 |
| 10.1 | Declaration of Conformity | 34 |
| 10.2 | Electromagnetic Compatibility | 34 |
| 10.3 | FCC Part 15 Compliance Statement | 34 |
| 10.4 | ICES-003 Compliance Statement | 35 |
| 11 | ATEX Certificate | 36 |
| 12 | EU Declaration of Conformity | 40 |
| 13 | IECEX Certification of Conformity - COC | 41 |
| 14 | Certificates China, Korea and Japan | 41 |

1 General Information

This user manual is intended to ensure proper handling and optimal functioning of the device. The user manual shall be read before commissioning the equipment and it shall be provided to all staff involved in transport, installation, operation, maintenance and repair. E+E Elektronik Ges.m.b.H. accepts no liability for any warranty or liability claims arising from this publication or improper handling of the product(s) described.

All information, technical data and diagrams included in this document are based on the information available at the time of writing. The document may contain technical inaccuracies and typographical errors. The contents will be revised on a regular basis and changes will be implemented in subsequent versions. The product(s) described and the contents of this document may be changed or improved at any time without prior notice.



All rights are reserved by E+E Elektronik Ges.m.b.H. No part of this document may be reproduced, published or publicly displayed in any form or by any means, nor may its contents be modified, translated, adapted, sold or disclosed to a third party without prior written permission of E+E Elektronik Ges.m.b.H.

PLEASE NOTE

Find this document and further product information on our website at <https://www.epluse.com/ee300ex>.

1.1 Explanation of Warning Notices and Symbols

Safety precautions

Precautionary statements warn of hazards in handling the device and provide information on their prevention. They are categorised into conventional  and Ex -specific warnings.

The safety instruction labeling is classified by hazard severity and is divided into the following groups:

EX-SPECIFIC HINT OR WARNING

This warning indicates specific regulations that must be observed in hazardous areas at risk of explosion.

If the safety instruction marked in this way is not followed, there is a health risk to humans and risk of damage to the measurement installation.

DANGER

Danger indicates hazards for persons. If the safety instruction marked in this way is not followed, the hazard will very likely result in severe injury or death.

WARNING

Warning indicates hazards for persons. If the safety instruction marked in this way is not followed, there is a risk of injury or death.

CAUTION

Caution indicates hazards for persons. If the safety instruction marked in this way is not followed, minor or moderate injuries may occur.

NOTICE

Notice signals danger to objects or data. If the notice is not observed, damage to property or data may occur.

Informative notes

Informative notes provide important information that is characterised by its relevance.

INFO

The information symbol indicates tips on handling the device or provides additional information on it. This information is useful to achieve optimum performance of the device.

The title field may deviate from "INFO" depending on the context. For instance, it may also read "PLEASE NOTE".

1.2 Safety Instructions

1.2.1. General Safety Instructions

NOTICE

Improper handling of the device may result in its damage.

- The EE300Ex enclosure, the sensing probe and the sensing elements shall not be exposed to unnecessary mechanical stress.
- The EE300Ex electronics are sensitive to electrostatic discharge (ESD). Take appropriate protective measures when touching it.
- Use the EE300Ex only as intended and observe all technical specifications.
- The device must be operated with the filter cap on at all times.
- When replacing a filter cap, ensure that there is no contact between the sensor element and the filter cap.
- When removing a filter cap make sure not to touch the sensing elements.
- For transmitter cleaning and filter cap replacement please observe the “Cleaning instructions” at www.epluse.com/ee300ex.

1.2.2. Intended Use

The EE300Ex intrinsically safe transmitter reliably measures relative humidity (RH) and temperature (T) in explosion hazard areas. The entire device can be placed in the explosion endangered area. The remote sensing probe enables classification up to T6.

WARNING

Non-compliance with the product documentation may cause safety risk for people and the entire measurement installation.

The manufacturer cannot be held responsible for damages as a result of incorrect handling, installation and maintenance of the device.

- Do not use the EE300Ex in aggressive gases.
- This device is not appropriate for safety, emergency stop or other critical applications where device malfunction or failure could cause injury to human beings.
- The device may not be manipulated with tools other than specifically described in this manual.

NOTICE

Failure to follow the instructions in this user manual may lead to measurement inaccuracy and device failures.

- The EE300Ex may only be operated under the conditions described in this user manual and within the specification included in chapter 9 Technical Data.
- Any unauthorised product modifications will invalidate all warranty claims. Modifications may only be carried out with express authorisation of E+E Elektronik Ges.m.b.H.!

1.2.3. Mounting, Start-up and Operation

The EE300Ex has been produced under state of the art manufacturing conditions, has been thoroughly tested and has left the factory after fulfilling all safety criteria. The manufacturer has taken all precautions to ensure safe operation of the device. The device shall be set up and installed in a way that does not impair its safe use. All applicable local and international safety guidelines for safe installation and operation of the device have to be observed. This user manual contains information and warnings that must be observed in order to ensure safe operation.

PLEASE NOTE

The manufacturer or his authorised agent can only be held liable in case of wilful or gross negligence. In any case, the scope of liability is limited to the corresponding amount of the order issued to the manufacturer. The manufacturer assumes no liability for damage caused by non-compliance with the applicable regulations, operating instructions or the specified operating conditions. Any consequential damage is excluded from liability.

⚠ WARNING

Non-compliance with the product documentation may result in accidents, personal injury or property damage.

- Mounting, installation, commissioning, start-up, operation and maintenance of the device may only be carried out by qualified staff. Such staff must be authorised by the operator of the facility to carry out the mentioned activities.
- The qualified staff must have read and understood this user manual and must follow the instructions contained within. The manufacturer accepts no responsibility for non-compliance with instructions, recommendations and warnings.
- All process and electrical connections must be thoroughly checked by authorised staff before commissioning the device.
- Do not install or start-up a device suspected to be faulty. Mark it clearly as faulty and remove it from the process.
- Service operations other than described in this user manual may only be performed by the manufacturer. A faulty device may only be investigated and possibly repaired by qualified, trained and authorised staff. If the fault cannot be fixed, the device shall be removed from the process.

1.3 Environmental Aspects

i PLEASE NOTE

Products from E+E Elektronik Ges.m.b.H. are developed and manufactured in compliance with relevant environmental protection requirements. Please observe local regulations for the disposal of the device.



For disposal, the individual components of the device must be separated according to local recycling regulations. The electronics shall be disposed of correctly as electronics waste.

1.4 ESD Protection



The sensing elements and the electronics board are ESD (electrostatic discharge) sensitive components of the device and must be handled as such. Failure to do so may damage the device by electrostatic discharge when touching exposed sensitive components.

2 Scope of Supply

- EE300Ex according to ordering guide
- User manual
- Inspection certificate according to DIN EN 10204-3.1

3 Product Description

3.1 General

The EE300Ex-M1 and the EE300Ex-M3 intrinsically safe transmitters are intended for the measurement of relative humidity (RH) and temperature (T) or temperature alone, in explosion hazard areas, in gas and dust up to Zone 0/20. The entire device can be placed in an explosion endangered area.

Supply

The transmitter may only be powered by an intrinsically safe power supply device or via protective barriers. It features a 2-wire 4 - 20 mA design and has two individually scalable analogue outputs.

Available Quantities and Units

| Parameter | | Measured | Calculated | Measurement Units |
|-------------------------------|----|----------|------------|---------------------------------------|
| Relative humidity | Uw | ✓ | | %RH |
| Temperature | T | ✓ | | °C, °F |
| Dew point temperature | Td | | ✓ | °C, °F |
| Wet bulb temperature | Tw | | ✓ | °C, °F |
| Frost point temperature | Tf | | ✓ | °C, °F |
| Ice bulb temperature | Ti | | ✓ | °C, °F |
| Absolute humidity | dv | | ✓ | g/m ³ , gr/ft ³ |
| Volume concentration | Wv | | ✓ | ppm |
| Water vapour partial pressure | e | | ✓ | mbar, psi |
| Specific enthalpy | h | | ✓ | kJ/kg, BTU/lb |
| Mixing ratio | r | | ✓ | g/kg, gr/lb |
| Water acitivity ¹⁾ | aw | ✓ | | - |
| Water content ¹⁾ | x | | ✓ | ppm |

1) Only valid for ATEX and IECEx.

Tab. 1 EE300Ex-M1 scope of measured and calculated quantities available as output

EE300Ex-M1 humidity and temperature transmitter types

| Type | | Pressure range | Temperature range | Probe Ø |
|------|---|-----------------------------------|-----------------------------|---------------|
| T1 | Wall mount | Ambient | -40...60 °C (-40...140 °F) | 12 mm (0.47") |
| T7 | Remote probe with cut-in fitting, pressure-tight | 0.01...20 bar (1.5...300 psi) | -40...180 °C (-40...356 °F) | 12 mm (0.47") |
| T9 | Remote probe with cut-in fitting, pressure-tight | 0.01...300 bar (0.15...4 351 psi) | -40...180 °C (-40...356 °F) | 12 mm (0.47") |
| T10 | Remote probe with sliding fitting for assembly / disassembly under pressure, pressure-tight | 0.01...20 bar (1.5...300 psi) | -40...180 °C (-40...356 °F) | 13 mm (0.51") |
| T22 | Remote probe for sensor retraction tool PN250, pressure-tight | 0.01...250 bar (0.15...3 626 psi) | -40...180 °C (-40...356 °F) | 12 mm (0.47") |

EE300Ex-M3 temperature transmitter types

| Type | | Pressure range | Temperature range | Probe Ø |
|------|--------------|-------------------------------|-----------------------------|--------------|
| T1 | Wall mount | Ambient | -40...60 °C (-40...140 °F) | 6 mm (0.24") |
| T24 | Remote probe | 0.01...20 bar (1.5...300 psi) | -70...200 °C (-94...392 °F) | 6 mm (0.24") |

Materials

The EE300Ex enclosure as well as all probes are made of stainless steel. Filter caps are available with different materials, stainless steel sinter, PTFE (Polytetrafluoroethylene) or metal grid. The probe cable of a remote probe is made of PFA (Perfluoralkoxy).

3.2 Dimensions

3.2.1. EE300Ex-M1: Humidity and Temperature Transmitter

Values in mm (inch)

Enclosure

Types: T1 / T7 / T9 / T10 / T22

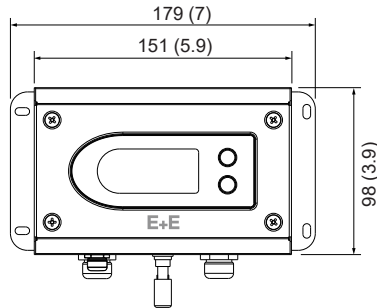

Type

T1: Wall mount

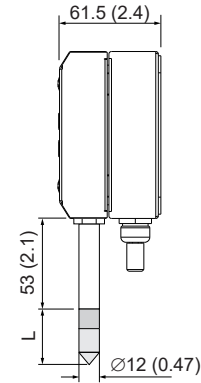

Types

T7: Remote probe 20 bar (300 psi)
T9: Remote probe 300 bar (4 351 psi) with weld or cut-in fitting

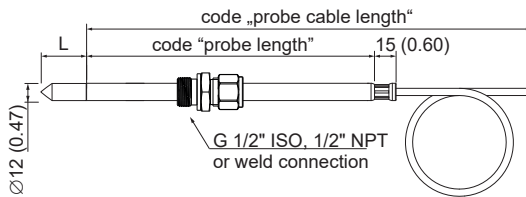

Type

T10: Remote probe 20 bar (300 psi) with sliding fitting for assembly / disassembly under pressure

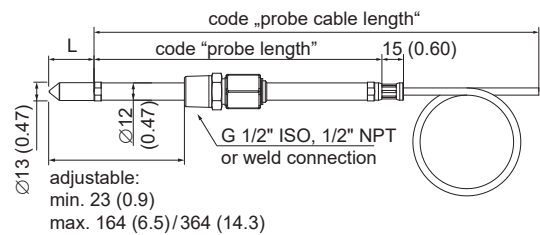

Types

T22: Remote probe for sensor retraction tool PN250

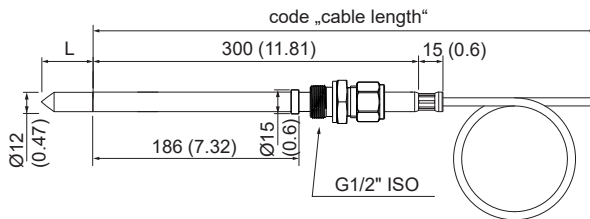

| L - filter length | mm (inch) |
|---|-----------|
| Stainless steel sintered filter | 33 (1.3) |
| PTFE filter, H ₂ O ₂ filter | 33 (1.3) |
| Stainless steel grid filter | 39 (1.5) |
| Oil filter | 32 (1.26) |

EX-SPECIFIC HINT OR WARNING

Pressure-tight probe up to 20 bar (300 psi) has a leak rate of $1 \cdot 10^{-4}$ mbar \cdot l/s (according to EN 1779 Method D1).

Pressure-tight probes up to 300 bar (4 351 psi) have a leak rate of $1 \cdot 10^{-6}$ mbar \cdot l/s (according to EN 1779 Method D1).

Leak rate can lead to gas accumulation in the enclosure.

3.2.2. EE300Ex-M3: Temperature Transmitter

Values in mm (inch)

Enclosure

Types: T1 / T24

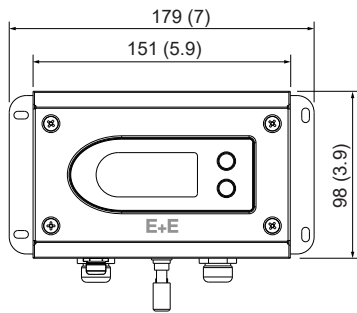

Type

T1: Wall mount

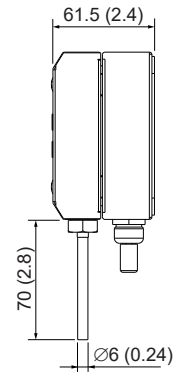

Type

T24: Remote probe 20 bar (300 psi) with cut-in fitting

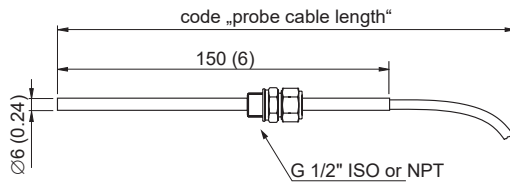

3.3 EE300Ex Labelling

Each EE300Ex is characterised for one certification. The transmitter has two labels. The “product label” shows the ordering code and type of the Ex Certificate. The “hazardous label” shows the Ex marking and the certificate number. See the examples below.

EE300Ex with IECEx, USA, Canada or Japan labeling must not be installed in the European Union.

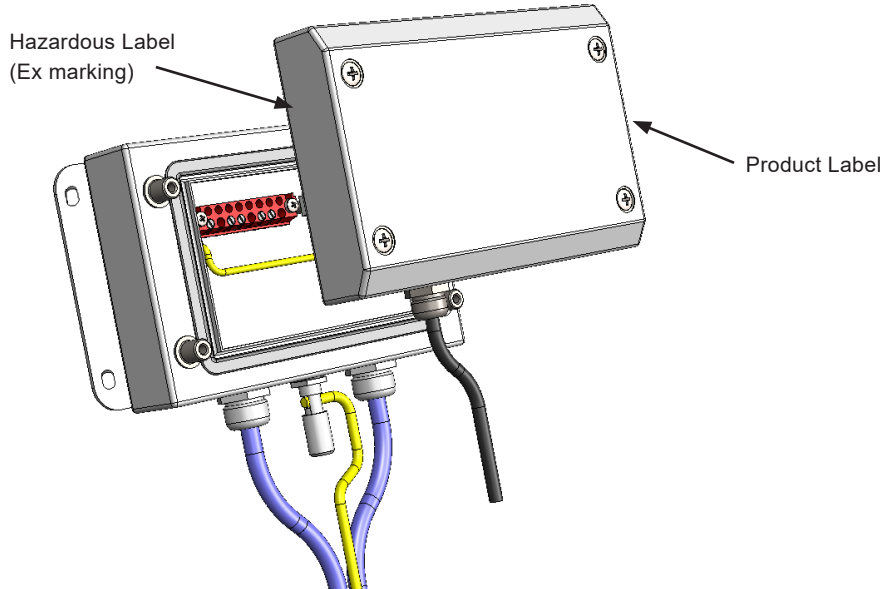

Fig. 1 EE300Ex label placement

ATEX hazardous label (for EE300Ex without display)

| | | |
|--|-----------------------------------|-------------------------|
| E+E Elektronik A-4209 Engerwitzdorf | | |
| TPS 13 ATEX 38892 003 X | | |
| II 1 G Ex ia IIC T4 Ga | U _i = 28 V | I _i = 100 mA |
| II 1 D Ex ia IIIC T ₂₀₀ 80°C Da | P _i = 700 mW | C _i = 2.2 nF |
| Electrical Data - See Manual | L _i = negligibly small | |
| -40 °C ≤ Ta ≤ 60 °C | Series: H | 272025 |

ATEX product label (Example) Order Code “EX1“

| | | |
|--|--|--|
| HUMIDITY / TEMPERATURE TRANSMITTER | | |
| EE300Ex-M1A6HS2T10D0E2K5L200PA25F4C1EX1 | | |
| CH1: RH: 4 - 20 mA = 0...100 %RH | | |
| CH2: T: 4 - 20 mA = 0...50 °C | 0123 | |
| Supply: (9 + RL * 0.02) - 28 V DC | S/N: 244293490009 www.epluse.com | |

IECEx hazardous label (for EE300Ex without display)

| | | |
|--|-----------------------------------|--------|
| E+E Elektronik A-4209 Engerwitzdorf | | |
| IECEx FMG 14.0017 X | | |
| Ex ia IIC T4 Ga | 6.4Vdc ≤ U _i ≤ 28Vdc | |
| Ex ia IIIC T131°C Da | I _i = 100mA | |
| Electrical Data - See Manual | P _i = 700mW | |
| -40°C ≤ Ta ≤ 60°C | C _i = 2,2nF | |
| | L _i = negligibly small | |
| | Series: H | 272025 |

IECEx product label (Example) Order Code “EX2”

| | | |
|--|--|--|
| HUMIDITY / TEMPERATURE TRANSMITTER | | |
| EE300Ex-M1A6HS2T10D0E2K5L200PA25F4C1EX2 | | |
| CH1: RH: 4 - 20 mA = 0...100 %RH | | |
| CH2: T: 4 - 20 mA = 0...50 °C | | |
| Supply: (9 + RL * 0.02) - 28 V DC | S/N: 244293490009 www.epluse.com | |

USA hazardous label (for EE300Ex without display)

| | | |
|--|---|-----------|
| E+E Elektronik A-4209 Engerwitzdorf | | |
| FM17US0302X | | |
| CL I,II,III DIV 1 GP ABCDEFG T4 | ZN 20 AEx ia IIIC T131°C Da | Series: H |
| CL I,II,III DIV 2 GP ABCDEFG T4 | 272025 | |
| CL I ZN 0 AEx ia IIC T4 Ga | Ta = -40°C to 60°C, Entity - M1_1309080, IP65 | |

USA product label (Example) Order Code “EX3”

| | | |
|--|--|--|
| HUMIDITY / TEMPERATURE TRANSMITTER | | |
| EE300Ex-M1A6HS2T10D0E2K5L200PA25F4C1EX3 | | |
| CH1: RH: 4 - 20 mA = 0...100 %RH | | |
| CH2: T: 4 - 20 mA = 0...50 °C | | |
| Supply: (9 + RL * 0.02) - 28 V DC | S/N: 244293490009 www.epluse.com | |

CANADA hazardous label (for EE300Ex without display)

| | | |
|--|---|-----------|
| E+E Elektronik A-4209 Engerwitzdorf | | |
| FM17CA0154X | | |
| CL I,II,III DIV 1 GP ABCDEFG T4 | ZN 20 Ex ia IIIC T131°C Da | Series: H |
| CL I,II,III DIV 2 GP ABCDEFG T4 | 272025 | |
| ZN 0 Ex ia IIC T4 Ga | Ta = -40°C to 60°C, Entity - M1_1309080, IP65 | |

CANADA product label (Example) Order Code “EX9”

| | | |
|--|--|--|
| HUMIDITY / TEMPERATURE TRANSMITTER | | |
| EE300Ex-M1A6HS2T10D0E2K5L200PA25F4C1EX9 | | |
| CH1: RH: 4 - 20 mA = 0...100 %RH | | |
| CH2: T: 4 - 20 mA = 0...50 °C | | |
| Supply: (9 + RL * 0.02) - 28 V DC | S/N: 244293490009 www.epluse.com | |

3.4 Certification

3.4.1. EUROPE

The EE300Ex transmitter fulfills the **ATEX Directives** on intrinsically safe operating equipment.

Applied standards for ATEX:

- **EN IEC 60079-0:2018+A11:2024**
- **EN 60079-11:2012**

The EU-Type Examination has been carried out by TÜV SÜD Product Service GmbH.

Certified to EU-Type Examination **TPS 13 ATEX 38892 003 X**.

Entity parameters $U_i = 28 \text{ V}$; $I_i = 100 \text{ mA}$; $P_i = 700 \text{ mW}$; $C_i = 2.2 \text{ nF}$; $L_i \approx 0 \text{ mH}$

Ex-Designation

Transmitter without display $\text{Ex} \text{ II 1G Ex ia IIC T4 Ga} / \text{Ex} \text{ II 1D Ex ia IIIC T}_{200} 80^\circ\text{C Da}$

Transmitter with display $\text{Ex} \text{ II 2G Ex ia IIC T4 Gb} / \text{Ex} \text{ II 1G Ex ia IIB T4 Ga}$

Remote probe $\text{Ex} \text{ II 1G Ex ia IIC T6...T1 Ga} / \text{Ex} \text{ II 1D Ex ia IIIC T}_{200} 80^\circ\text{C...}200^\circ\text{C Da}$

Working temperature range for the probes:

Specification of the temperature class „TKG“ for use in gas area exposed to explosion hazards and „TKD“ for use in dust area exposed to explosion hazards as a function of the ambient temperature „Tamb“ for the humidity and temperature probe and the temperature probe:

| TKG | TKD | Humidity and Temperature Probe | TKG | TKD | Temperature Probe |
|-----|--------|--|-----|--------|--|
| T6 | 80 °C | $-40 \text{ °C} \leq T_{amb} \leq +60 \text{ °C}$ | T6 | 80 °C | $-70 \text{ °C} \leq T_{amb} \leq +60 \text{ °C}$ |
| T5 | 95 °C | $-40 \text{ °C} \leq T_{amb} \leq +75 \text{ °C}$ | T5 | 95 °C | $-70 \text{ °C} \leq T_{amb} \leq +75 \text{ °C}$ |
| T4 | 130 °C | $-40 \text{ °C} \leq T_{amb} \leq +110 \text{ °C}$ | T4 | 130 °C | $-70 \text{ °C} \leq T_{amb} \leq +110 \text{ °C}$ |
| T3 | 195 °C | $-40 \text{ °C} \leq T_{amb} \leq +175 \text{ °C}$ | T3 | 195 °C | $-70 \text{ °C} \leq T_{amb} \leq +175 \text{ °C}$ |
| T2 | 200 °C | $-40 \text{ °C} \leq T_{amb} \leq +180 \text{ °C}$ | T2 | 220 °C | $-70 \text{ °C} \leq T_{amb} \leq +200 \text{ °C}$ |
| T1 | 200 °C | $-40 \text{ °C} \leq T_{amb} \leq +180 \text{ °C}$ | T1 | 220 °C | $-70 \text{ °C} \leq T_{amb} \leq +200 \text{ °C}$ |

3.4.2. INTERNATIONAL

Applied Standard for IECEx:

- **IEC 60079-0:2017**
- **IEC 60079-11:2023**

The Certificate of Conformity has been carried out by FM Approvals.

Certificate No.: **IECEx FMG 14.0017 X**

Entity parameters: $6.4 \text{ Vdc} \leq U_i \leq 28 \text{ Vdc}$; $I_i = 100 \text{ mA}$; $P_i = 700 \text{ mW}$; $C_i = 2.2 \text{ nF}$; $L_i = 0 \text{ mH}$

Ex-Designation

Transmitter without display $\text{Ex ia IIC T4 Ga} / \text{Ex ia IIIC T}131^\circ\text{C Da}$

Transmitter with display $\text{Ex ia IIC T4 Gb} / \text{Ex ia IIB T4 Ga}$

Remote probe $\text{Ex ia IIC T6-T1 Ga} / \text{Ex ia IIIC T}80^\circ\text{C Da}$

Humidity and temperature probe:

- T6 temperature class based on $-40 \text{ °C} (-40 \text{ °F}) \leq T_a \leq 60 \text{ °C} (140 \text{ °F})$
- T5 temperature class based on $-40 \text{ °C} (-40 \text{ °F}) \leq T_a \leq 75 \text{ °C} (167 \text{ °F})$
- T4 temperature class based on $-40 \text{ °C} (-40 \text{ °F}) \leq T_a \leq 110 \text{ °C} (230 \text{ °F})$
- T3 temperature class based on $-40 \text{ °C} (-40 \text{ °F}) \leq T_a \leq 175 \text{ °C} (347 \text{ °F})$
- T2 temperature class based on $-40 \text{ °C} (-40 \text{ °F}) \leq T_a \leq 180 \text{ °C} (356 \text{ °F})$
- T1 temperature class based on $-40 \text{ °C} (-40 \text{ °F}) \leq T_a \leq 180 \text{ °C} (356 \text{ °F})$

Certificate Dust:

Remote transmitter: 20-AV4BO-0256X

Transmitter without Display: 20-AV4BO-0255X

Entity parameters: $6.4 \text{ Vdc} \leq U_i \leq 28 \text{ Vdc}$; $I_i = 100 \text{ mA}$; $P_i = 700 \text{ mW}$; $C_i = 2.2 \text{ nF}$; $L_i = 0 \text{ mH}$

Ex-Designation

Transmitter (without display): Ex ia IIC T4 $-40 \text{ }^\circ\text{C} \leq T_{amb} \leq +60 \text{ }^\circ\text{C}$
Ex iaD 20 IP6X T131 $^\circ\text{C}$ $-40 \text{ }^\circ\text{C} \leq T_{amb} \leq +60 \text{ }^\circ\text{C}$

Transmitter (with display): Ex ia IIC T4 $-40 \text{ }^\circ\text{C} \leq T_{amb} \leq +60 \text{ }^\circ\text{C}$ (up to Zone 1)
Ex ia IIB T4 $-40 \text{ }^\circ\text{C} \leq T_{amb} \leq +60 \text{ }^\circ\text{C}$

Remote sensing probe : Ex ia IIC T6-T1 / Ex iaD 20 IP6X T80 $^\circ\text{C}$ $-40 \text{ }^\circ\text{C} \leq T_{amb} \leq +60 \text{ }^\circ\text{C}$

Humidity and temperature probe:

- T6 temperature class based on $-40 \text{ }^\circ\text{C}$ ($-40 \text{ }^\circ\text{F}$) $\leq T_a \leq 60 \text{ }^\circ\text{C}$ ($140 \text{ }^\circ\text{F}$)
- T5 temperature class based on $-40 \text{ }^\circ\text{C}$ ($-40 \text{ }^\circ\text{F}$) $\leq T_a \leq 75 \text{ }^\circ\text{C}$ ($167 \text{ }^\circ\text{F}$)
- T4 temperature class based on $-40 \text{ }^\circ\text{C}$ ($-40 \text{ }^\circ\text{F}$) $\leq T_a \leq 110 \text{ }^\circ\text{C}$ ($230 \text{ }^\circ\text{F}$)
- T3 temperature class based on $-40 \text{ }^\circ\text{C}$ ($-40 \text{ }^\circ\text{F}$) $\leq T_a \leq 175 \text{ }^\circ\text{C}$ ($347 \text{ }^\circ\text{F}$)
- T2 temperature class based on $-40 \text{ }^\circ\text{C}$ ($-40 \text{ }^\circ\text{F}$) $\leq T_a \leq 180 \text{ }^\circ\text{C}$ ($356 \text{ }^\circ\text{F}$)
- T1 temperature class based on $-40 \text{ }^\circ\text{C}$ ($-40 \text{ }^\circ\text{F}$) $\leq T_a \leq 180 \text{ }^\circ\text{C}$ ($356 \text{ }^\circ\text{F}$)

Temperature probe:

- T6 temperature class based on $-70 \text{ }^\circ\text{C}$ ($-94 \text{ }^\circ\text{F}$) $\leq T_a \leq 60 \text{ }^\circ\text{C}$ ($140 \text{ }^\circ\text{F}$)
- T5 temperature class based on $-70 \text{ }^\circ\text{C}$ ($-94 \text{ }^\circ\text{F}$) $\leq T_a \leq 75 \text{ }^\circ\text{C}$ ($167 \text{ }^\circ\text{F}$)
- T4 temperature class based on $-70 \text{ }^\circ\text{C}$ ($-94 \text{ }^\circ\text{F}$) $\leq T_a \leq 110 \text{ }^\circ\text{C}$ ($230 \text{ }^\circ\text{F}$)
- T3 temperature class based on $-70 \text{ }^\circ\text{C}$ ($-94 \text{ }^\circ\text{F}$) $\leq T_a \leq 175 \text{ }^\circ\text{C}$ ($347 \text{ }^\circ\text{F}$)
- T2 temperature class based on $-70 \text{ }^\circ\text{C}$ ($-94 \text{ }^\circ\text{F}$) $\leq T_a \leq 200 \text{ }^\circ\text{C}$ ($392 \text{ }^\circ\text{F}$)
- T1 temperature class based on $-70 \text{ }^\circ\text{C}$ ($-94 \text{ }^\circ\text{F}$) $\leq T_a \leq 200 \text{ }^\circ\text{C}$ ($392 \text{ }^\circ\text{F}$)

In area with explosive gas group IIC, the EE300Ex must be mounted in zone 1.

In gas Ex area of group IIB the installation in zone 0 is permitted.

Conditions for safe use:

- Applying of the operating instructions provided by the manufacturer (document number: BA_EE300Ex_e_1.14, BA_HA011068)
- The serial software configuration port of the EE300Ex may only be used with the Product Configuration Adapter (EE-PCA) and the Connection Cable (HA011068).
- There is no display permitted in gas hazard area Zone 0 for group IIC and in the dust hazard area.
- There is no filter cap made of plastic or with plastic parts permitted in the gas hazard area Zone 0 for group IIC.
- EE300Ex remote probe (temperature – humidity 12 mm and temperature 6 mm) must be earthed. For use EE300Ex with remote probe in Zone 0, the remote probe must be installed in a metallic grounded protective tube.
- EE300Ex with the connector option may not be used in dust hazard area and in gas hazard area Zone 0 for group IIC.
- In case of using both measuring channels, each channel must be driven separately with its own galvanic safety barrier.

3.4.5. JAPAN

Type Approval Certificate has been carried out by TIIS.

Certificate No.: TC22061

Entity parameters: $U_i = 28 \text{ Vdc}$; $I_i = 100 \text{ mA}$; $P_i = 700 \text{ mW}$; $C_i = 2.2 \text{ nF}$; $L_i = 0 \text{ mH}$

Ex-Designation

Ex ia IIC T4 Gb ($T_a = -40 \text{ }^\circ\text{C}$ to $60 \text{ }^\circ\text{C}$)

No installation in Ga permitted. The EE300Ex must be mounted in Zone 1 or Zone 2.

No dust certification or temperature probe without humidity.

No plastic filter caps allowed.

4 Display (Optional)

EX-SPECIFIC HINT OR WARNING

The use of a display is not permitted in the gas hazard area for EPL Ga IIC and in the dust hazard area for IIIA, IIIB and IIIC.

EX-SPECIFIC HINT OR WARNING

For TIIS (Japan certification) and order code EX6, no display is permitted in Ga.

EX-SPECIFIC HINT OR WARNING

The display film must be protected from direct sunlight.

The display shows the measurands on the outputs CH1 (top row) and CH2 (bottom row), according to the ordering code.

The top key changes the visualisation of the calculated parameter on the top row. The bottom key changes the visualisation of the calculated parameter on the bottom row. Changing the displayed quantities does not change the parameters on the output CH1 and CH2.

PLEASE NOTE

Relationship between analogue output and display:

For the analogue outputs, a measurand (e.g.: temperature T) with a scaling (e.g.: 0 - 50) must be selected when ordering. If this measurand is selected on the display and the measured value is within the scaling, the current value is shown on the display. However, if the measured value is above or below the defined scaling range, the upper or lower value of the scaling is shown on the display and the measurand (e.g.: T) flashes. The measured value displayed matches the current value output at 4 or 20 mA.

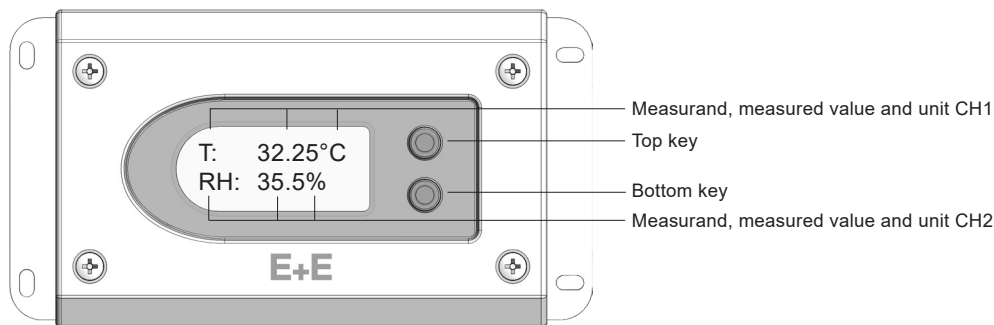

5 Mounting and Installation

5.1 General

EX-SPECIFIC HINT OR WARNING

The EE300Ex is certified according to ATEX 2014/34/EU Directive and IECEx Scheme.

EX-SPECIFIC HINT OR WARNING

The use of the EE300Ex in explosion hazard areas is only permitted under following atmospheric conditions:
 $-20\text{ °C } (-4\text{ °F}) \leq T \leq 40\text{ °C } (104\text{ °F})$
 $0.8\text{ bar } (12\text{ psi}) \leq p \leq 1.1\text{ bar } (16\text{ psi})$
 air normally 21 % (v/v)

The EE300Ex may be employed beyond above atmospheric conditions range only observing EN 1127-1 and only in line with the manufacturer's instructions.

EX-SPECIFIC HINT OR WARNING

The EE300Ex may only be supplied by intrinsically safe power supply devices or via protective barriers. This also applies if only the probe is located inside the explosion hazard area.

The rules for wiring intrinsically safe electrical circuits according to EN 60079-14, EN 60079-25, IEC 60079-14, IEC 60079-25 (proof of intrinsic safety in the system description) as well as all applicable national regulations must be strictly observed.

EX-SPECIFIC HINT OR WARNING

The intrinsically safe circuitry shall include an overvoltage protection device if the analysis according to EN 1127-1 reveals a risk of lightning strike.

Requirements for the installation of overvoltage protection devices are defined in European standard EN 60079-25.

EX-SPECIFIC HINT OR WARNING

The manufacturing date of each EE300Ex is shown on the hazardous product label, at the bottom right corner, as follows:

WWYYYY

WW week of the year

YYYY year

5.2 Enclosure

The EE300Ex features a modular design and consists of:

- Bottom section with the connection and grounding terminals
- Front section with the electronics and the probe

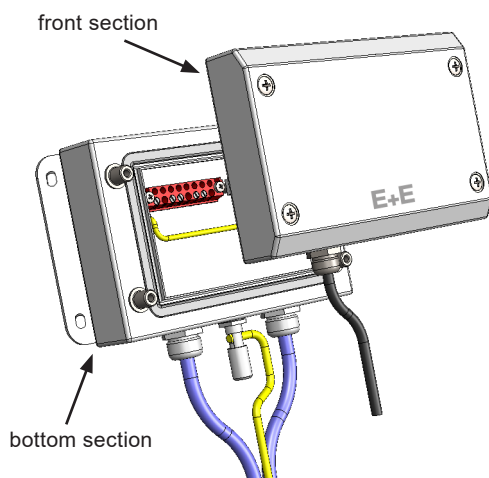

Drilling Pattern for Installing the Enclosure

Values in mm (inch)

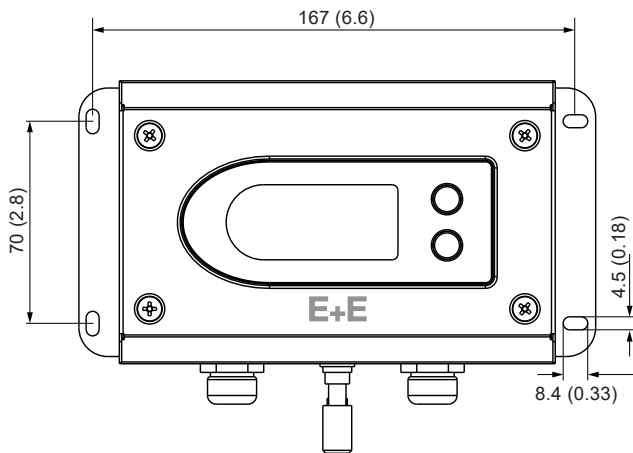

To mount the bottom section,
use 4 screws diameter < 4.5 mm (0.18")

EX-SPECIFIC HINT OR WARNING

When the front section has been removed, e.g. for calibration, the empty bottom section shall be protected against dirt and electrostatic charge with the blind front cover HA011401 (please refer to chapter 8 Accessories).

EX-SPECIFIC HINT OR WARNING

Unused cable glands shall be closed with appropriate sealing plugs (please refer to chapter 8 Accessories).

5.3 Assembly in Category 1 (Zone 0 / 20)**EX-SPECIFIC HINT OR WARNING**

Only intrinsically safe power supply devices are approved to supply EE300Ex in category 1.

EX-SPECIFIC HINT OR WARNING

In areas belonging to gas group IIC, it must be ensured that during installation and operation, the possibility of impact and friction sparks has been excluded in rarely occurring fault situations.

EX-SPECIFIC HINT OR WARNING

Work on open transmitter must only be performed if it is guaranteed that no explosive atmosphere is present.

EX-SPECIFIC HINT OR WARNING

In category 1, the transmitter line should be laid in an earthed metallic protective hose. Ensure that there are no dust or fibers and flyings deposits in the protective tube.

EX-SPECIFIC HINT OR WARNING

CH1 and CH2 must be galvanically isolated from one another during operation.

EX-SPECIFIC HINT OR WARNING

There is no display permitted in the gas hazard area EPL Ga for Group IIC and in the dust hazard area for groups IIIA, IIIB and IIIC.

EX-SPECIFIC HINT OR WARNING

The probe for wall mount is not permitted to be used for Zone bushing.

EX-SPECIFIC HINT OR WARNING

No mounting in Zone 0 and dust Ex for TIIS (Japan certification) order code EX6 allowed.

EE300Ex (wall mount) 1 channel via intrinsically safe power supply device:

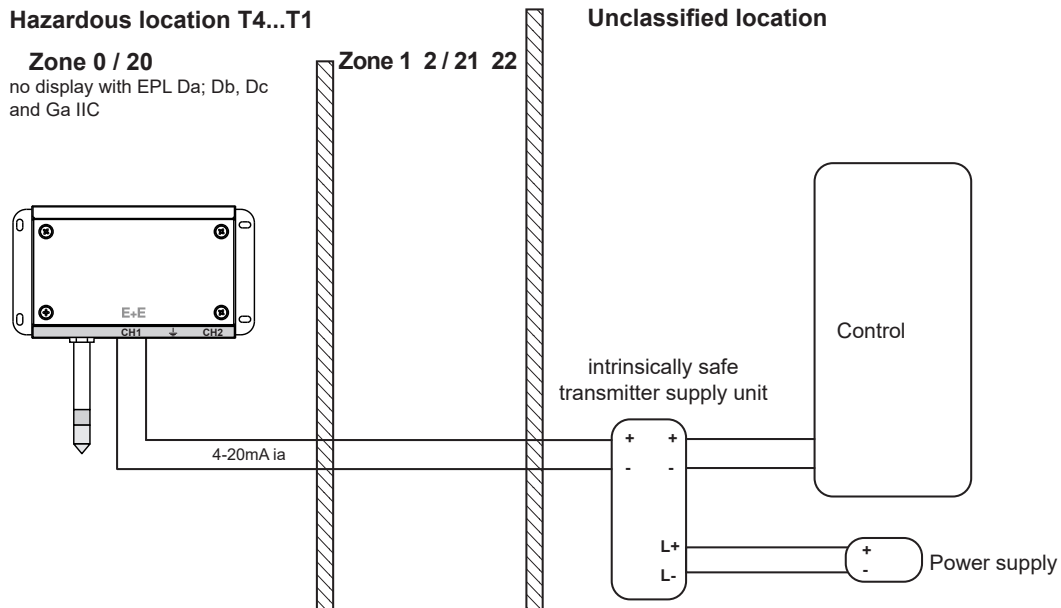

EE300Ex (with remote probe) 2 channels via intrinsically safe power supply device:

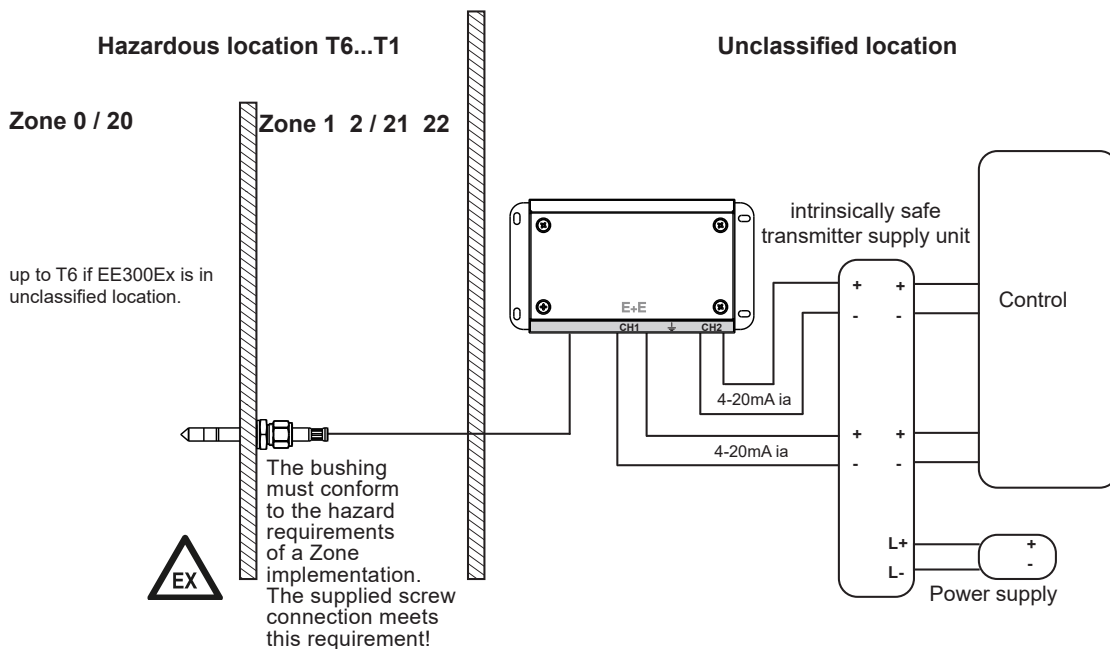

5.4 Assembly in Categories 2 and 3 (Zone 1, 2 / 21 , 22)

EX-SPECIFIC HINT OR WARNING

Only intrinsically safe power supply devices and protective barriers are approved to supply EE300Ex in category 2 and 3.

EX-SPECIFIC HINT OR WARNING

No display is permitted in the dust hazard area (Group III).

EX-SPECIFIC HINT OR WARNING

CH1 and CH2 must be galvanically isolated from one another during operation.

EX-SPECIFIC HINT OR WARNING

The probe for wall mount is not permitted to be used for Zone bushing.

EE300Ex (wall mount) 1 channel via intrinsically safe power supply device:

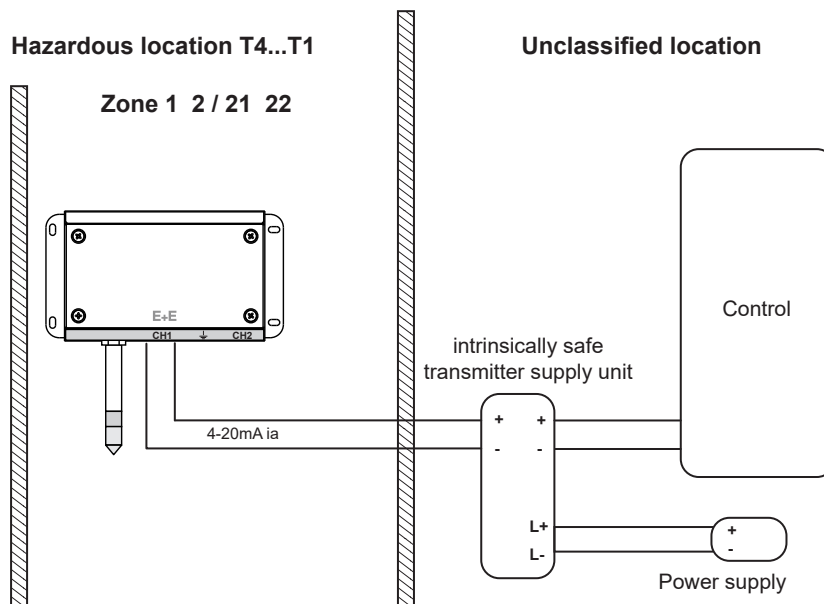

EE300Ex (with remote probe) 2 channels via intrinsically safe power supply device:

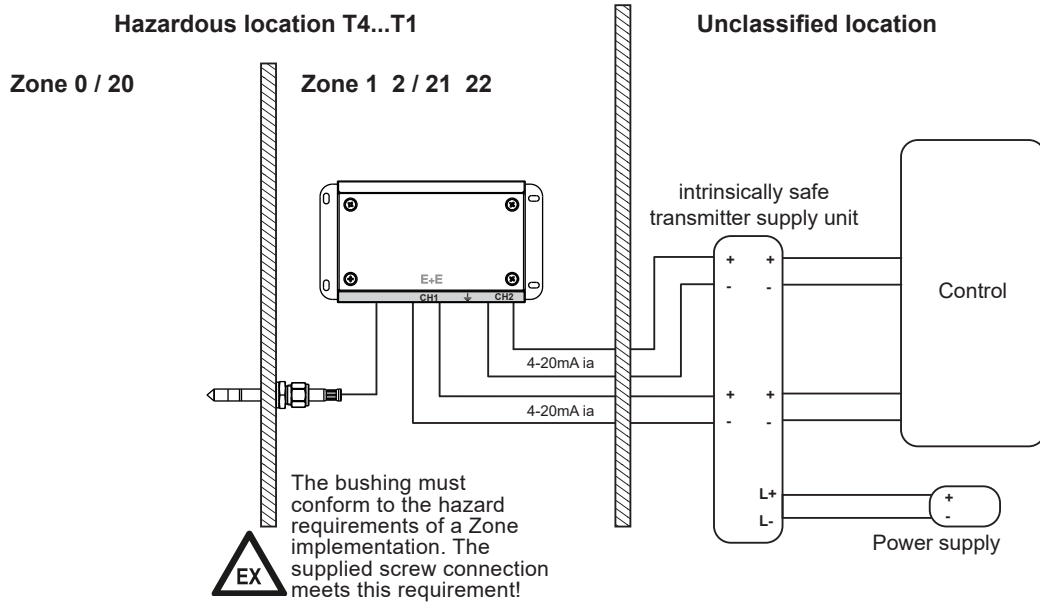

5.5 Probe Mounting

i PLEASE NOTE

The probe of the EE300Ex transmitter shall be located at the most representative location for RH and T of the process to be monitored.

For accurate measurement it is of paramount importance to avoid temperature gradients along the probe.

Whenever possible, install the entire probe inside the environment to be monitored. If the probe is installed through a wall, the biggest part of the probe shall be located in the target environment and the rest shall be thermally well insulated.

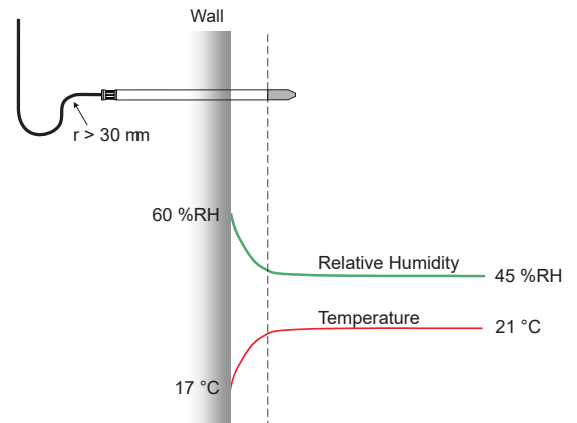

i PLEASE NOTE

The probe shall be mounted horizontally or vertically, with the tip of the probe pointing downwards.

In applications where condensation is likely to happen:

- The cable shall form a drip loop close to the probe.
- Use the drip water protection (please refer to the [Accessories](#) datasheet, code HA010503) for vertically mounted probe.

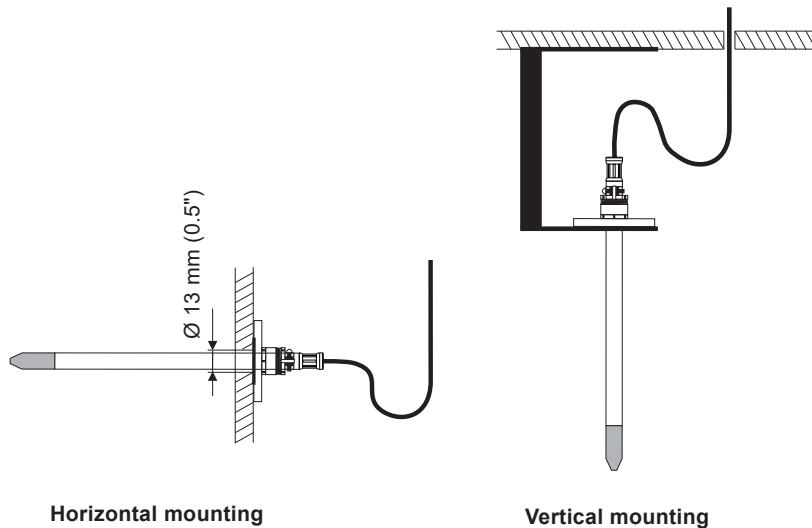

EX EX-SPECIFIC HINT OR WARNING

Mechanical ambient conditions:

Ensure appropriate mechanical stability and sealing of the probe mounting taking into account specific influences at the site, such as vibrations, shocks or temperature changes.

EX EX-SPECIFIC HINT OR WARNING

The probe and the cabling shall be handled and installed to avoid electrostatic charges. (e.g. metal hose).

EX EX-SPECIFIC HINT OR WARNING

Filter caps:

The following filter caps offer good protection against electrostatic discharge for explosion group IIB, but are not permitted for use in EPL Ga IIC:

- Membrane filter (order code F2)
- PTFE filter (order code F5)
- Membrane on stainless steel body (order code F10)
- PTFE on stainless steel body (order code F11)
- H₂O₂ filter (order code F12)

The following filter caps are permitted for use in EPL Ga IIC:

- Stainless steel sintered (order code F4)
- Stainless steel grid (order code F9)
- Oil (order code F13 or F18)

EX EX-SPECIFIC HINT OR WARNING

Filter caps F2, F5, F10, F11 and F12 not allowed for TIIS (Japan certification) order code EX6.

5.5.1. Probe Feed-through with Cut-in Fitting

EX EX-SPECIFIC HINT OR WARNING

The feed-through with cut-in fitting (ordering code PA20, PA21, PA22) can be used as zone bushing. For this, the tightness of its mounting into the Zone separation wall must correspond to IP67.

Once mounted, the cut-in fitting creates a permanent clamping ring onto the probe.

⚠ WARNING

Safety instructions for pressure-tight feed-through:

- Do not assemble the probe and tighten the feed-through if the plant is under pressure.
- The plant must not be vented by releasing the nut (A).
- Use appropriate seal on conical probe threads.
- Never rotate the screw connection body (B) but hold the screw connection body (B) securely and turn the nut (A).
- Avoid unnecessary disassembly of pipe screw connections.
- Position the cut in fitting >75 mm (2.95") from the end of the filter cap to the end of the fitting!
For a probe length of 65 mm a cut-in fitting is not possible.

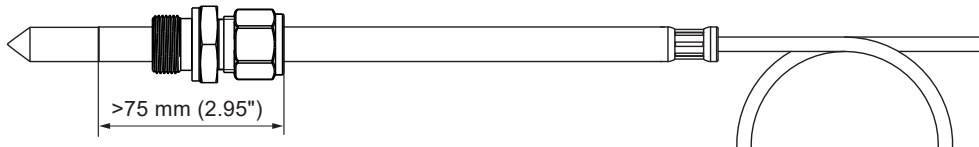

Installation instructions:

- Tighten the nut (A) finger-tight.
- Mark the nut (A) at 6 o'clock position.
- Hold the screw connection body (B) tight and tighten the nut (A) with 1 ¼ turns till 9 o'clock position.

Assembly with high pressure applications and applications with a high security factor:

- Tighten the nut (A) until the probe (C) can no longer be turned by hand and moved axially in the feed-through.
- Mark the nut (A) at 6 o'clock position.
- Hold the screw connection body (B) tight and tighten the nut (A) with 1 ¼ turns to 9 o'clock position.

Re-mounting:

- Slide the measurement probe with clamping ring into the fitting as far as it goes.
- Tighten the nut finger-tight, then tighten by approx. a ¼ turn using a spanner.

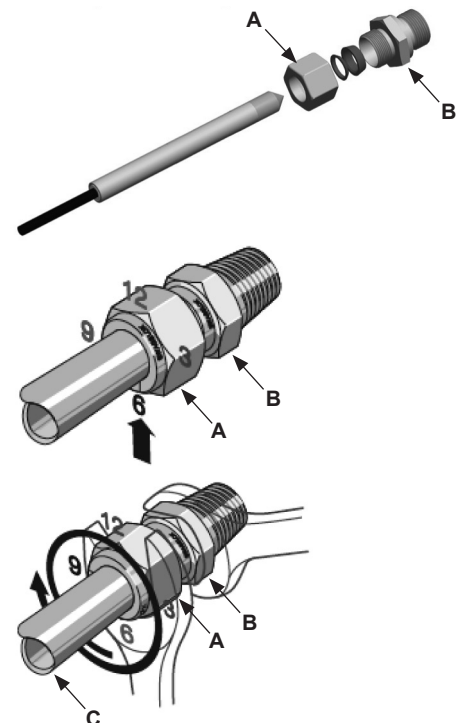

5.5.2. Mounting Flange

⚠ EX-SPECIFIC HINT OR WARNING

The optional mounting flange (please refer to the [Accessories](#) datasheet) may not be used as zone bushing. When installed with the mounting flange, the hazard areas on the filter cap side and at the cable outlet side must be of the same category.

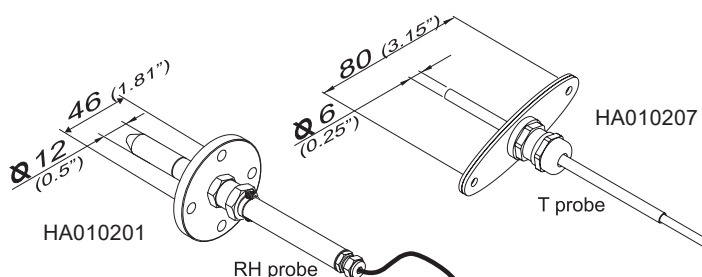

5.5.3. Ball Valve and Sliding Fitting

The optional ball valve HA011403 (ATEX certified) allows for the probe to be mounted or removed without interrupting the process to be monitored. Install the sensor head at right angles to the direction of flow.

EX-SPECIFIC HINT OR WARNING

Only ball valves approved for use in explosion hazard areas are permitted.

The two metal sealing rings (refer to illustration) should be replaced after each unscrewing.

Mounting the probe

The process temperature may not deviate from the mounting temperature by more than ± 40 °C (72 °F). The maximum permitted process pressure during mounting is 10 bar (145 psi).

- Mount the probe onto the ball valve with the ball valve closed.
- Open the ball valve.
- Slide the probe through the ball valve into the process to the desired immersion depth. For rather high process pressure a manual pressing tool might be needed for sliding easily the probe into the process.
- For secure probe installation, the closing nut shall be tightened with a torque of 30 Nm. The use of a torque wrench is recommended for this purpose.

WARNING

If the tightening torque is too low, the clamping force (fastening force) will be too low.

Consequently, there is a risk for the probe being pushed out by the process pressure.

If a torque wrench is not available, turn first the closing nut by hand as tight as possible, then turn another approx. 50° using a suitable open-ended spanner.

NOTICE

An excessive tightening torque may cause permanent deformation of the clamping sleeve and of the probe. This makes the removal and re-mounting difficult or even impossible.

The two metal sealing rings (see figure) shall be replaced by new ones after each removal of the probe.

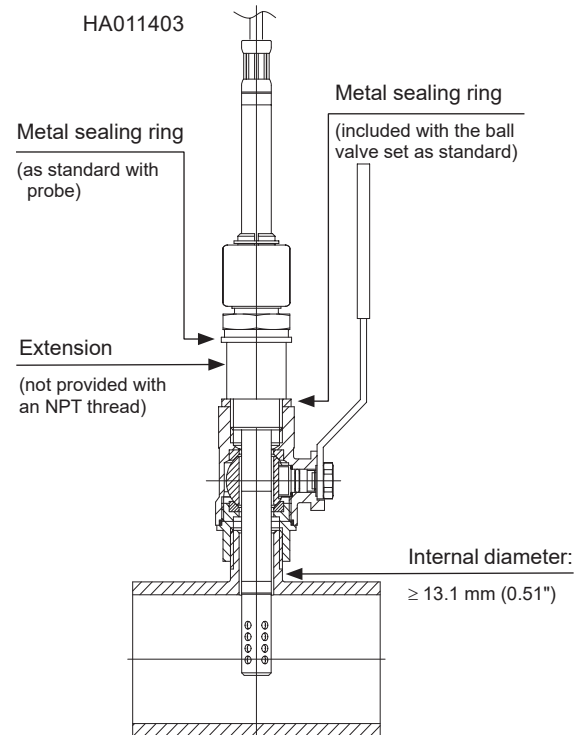

Removing the probe

⚠ WARNING

Completely releasing the closing nut will eject the probe. Fix the fitting body nut when releasing the closing nut.

- Hold the probe firmly in place. While doing so, do not bend the probe cable.
 - Slowly release the closing-nut using a spanner only until the process pressure pushes out the probe. Do not release the closing-nut completely!
 - After the probe has been pushed all the way back, close the ball valve.
 - The probe can be now removed from the ball valve.
- During mounting and removal, ensure that O-ring 1 is correctly installed.

Replace a damaged O-ring by an original new one, order code HA050308, O-ring type: 13x1.5 mm (0.5"x 0.06") - FKM-60.

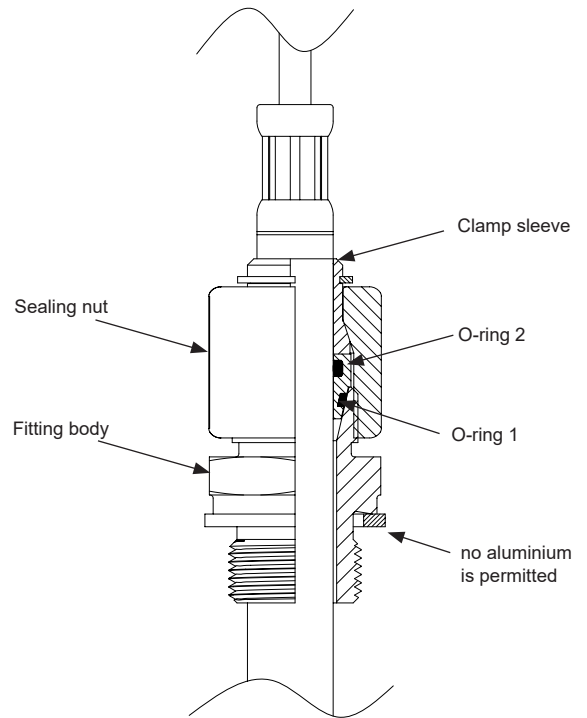

5.5.4. The Optional Probe Retraction Tool

⚠ WARNING

The operating instructions of the probe retraction tool must be strictly observed.

The probe of the EE300Ex model T22 can be installed into a pressurised environment up to 300 bar (4 350 psi) using the sensor retraction tools ZM-WA-025-040-EST or BG-WA-103-045-EST.

The scope of supply of the EE300Ex model T22 includes the copper sealing for the Swagelok feed-through.

⚠ WARNING

Make sure that the sensor retraction tool is in the "SERVICE" position (see manual of the sensor retraction tool).

- Before installing the transmitter, dismantle the closing plug 1/2" using a hexagonal 10 mm wrench and "park" it at the thread hole M10 designed for that purpose.



- Insert the probe with the copper sealing, the Swagelok union nut, the Swagelok fitting and protective cover into the probe retraction tool as far as possible.

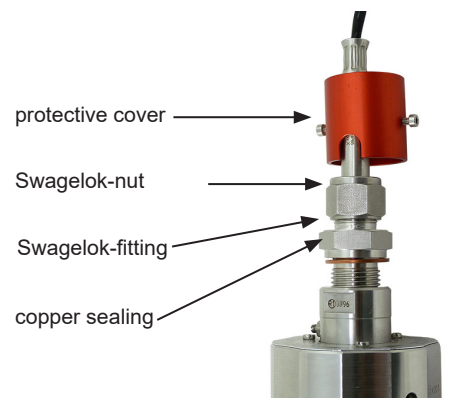

- Fasten the Swagelok ½" fitting of the sensor retraction tool with appropriate wrench. Do not forget the copper sealing!
- Close the Swagelok union nut with cutting ring finger-tight by hand. Then adjust the probe.
- Use the appropriate wrench to tighten the union nut (A) just firmly enough that the screw connection (B) cannot be moved manually. Mark the nut at the 6 o'clock position.
- Hold the screw connection body (B) tight and tighten the union nuts (A) with 1 ¼ turns to the 9 o'clock position.
- Mounting the protective cover for the Swagelok feedthrough:
 1. Push the protective cover down to the adjusting device. The screws shall point to the flat area.
 2. Tighten the M3 screws.

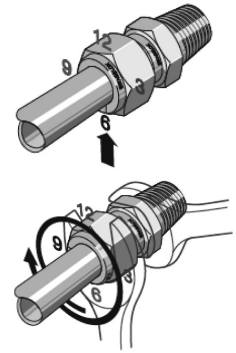

6 Electrical Connection

6.1 General

EX-SPECIFIC HINT OR WARNING

It is essential that installation, electrical connection, commissioning, operation and maintenance in explosion hazard areas are only carried out by trained specialist staff who are authorised by the system operator.

WARNING

Incorrect installation, wiring or power supply may cause overheating and result in personal injury or property damage.

Cables must not be under voltage during electrical installation and connection or disconnection, especially at terminal connections on circuit boards. For correct cabling, always observe the presented wiring diagram for the product version used.

The manufacturer cannot be held responsible for personal injury or damage to property caused by incorrect handling, installation, wiring, power supply or maintenance of the device.

EX-SPECIFIC HINT OR WARNING

The installation in an explosion hazard area shall comply with EN 60079-14, EN 60079-25 or IEC 60079-14, IEC 60079-25. Repair and maintenance shall be performed according to EN 60079-17 or IEC 60079-17 and EN 60079-19 or IEC 60079-19.

All relevant national regulations shall be strictly observed.

NOTICE

The EE300Ex transmitter is a loop powered (2-wire) device, both channels (outputs) are galvanic isolated. **For proper operation, Channel 1 (CH1) must always be connected.** Channel 2 (CH2) may be connected only if necessary.

EX-SPECIFIC HINT OR WARNING

Wire ends shall be fitted with appropriate wire end ferrules. While connected to the terminals, the air gap must be min. 2 mm (0.08") between the wires and min. 6 mm (0.2") between CH1 and CH2.

NOTICE

Do not shorten or extend the probe cable. Changing the probe cable length has a strong negative effect on the measurement performance and may lead to EE300Ex failure.

6.2 Terminal Assignment

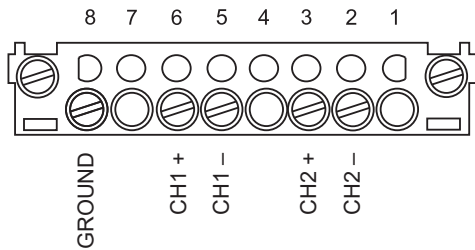

NOTICE

Please note the following when assembling the enclosure:

It is essential that the pin header fits correctly into the contacts of the terminal block. To ensure this, the enclosure parts must be brought together in parallel. Please refer to the illustration below.

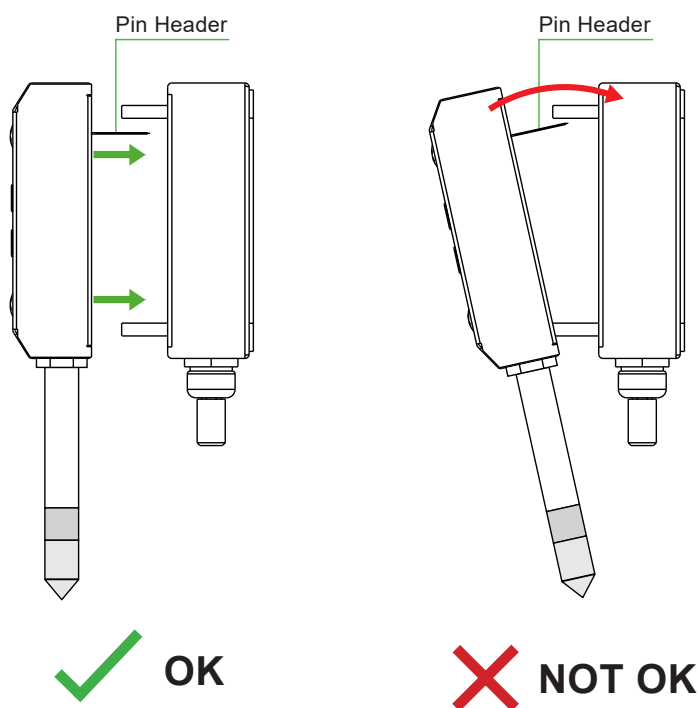

Fig. 2 EE300Ex assembly of the enclosure parts for correct electrical connection

6.3 Grounding and Potential Equalization

EX-SPECIFIC HINT OR WARNING

The EE300Ex shall be integrated into the potential equalization to avoid hazards from electrostatic charges. The grounding shall comply with EN60079-14, EN60079-25 or IEC60079-14, IEC60079-25. A remote probe shall also be grounded using a screw connection with a maximum of 1 MΩ in the potential equalization.

EX-SPECIFIC HINT OR WARNING

The ground conductor or the potential equalization connection must have a cross-section of 4 mm² (0.006 in²) for the external grounding. Stranded wires shall be fitted with suitable wire-end sleeves.

For external grounding, one of the two equivalent alternatives is available (see figure below).

EX-SPECIFIC HINT OR WARNING

The resistance of the ground connection of the intrinsically safe barrier shall be max. 1 Ohm.

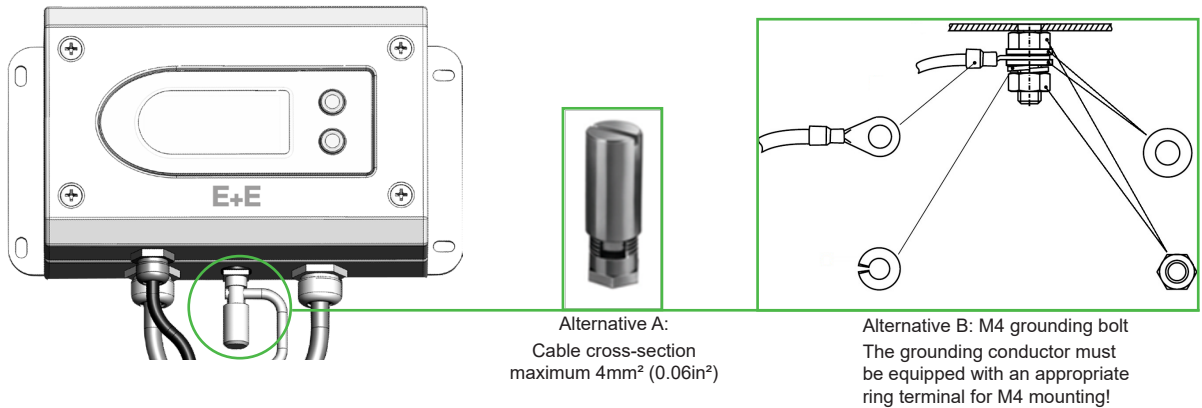
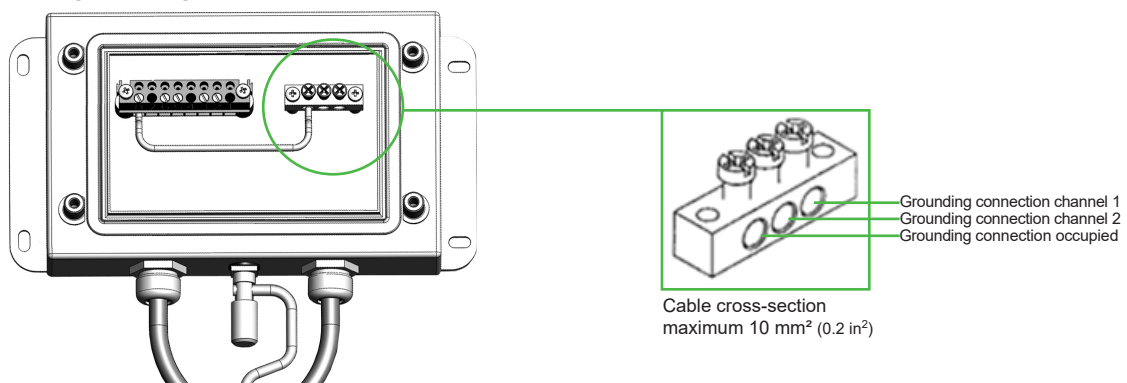
External grounding:**Internal grounding:**

Internal or external connection is sufficient for grounding.

6.4 Connection Cable

EX-SPECIFIC HINT OR WARNING

A shielded cable shall be used. The shield must be grounded at one end only: at the EE300Ex side.

EX-SPECIFIC HINT OR WARNING

The connection cable shall comply to the following specifications for ATEX, as required by EN60079-14 and EN60079-25:

- Maximum cross-section 1.5 mm² (0.02 in²)
- Single stranded wire diameter $\geq 0.1\text{mm}$ (0.004")
- Test voltage wire-wire $\geq 500\text{ V AC eff.}$
- Test voltage wire-shield (if a cable with shield is used): $\geq 500\text{ V AC eff.}$
- Cable inductivity, cable capacity and conductor resistance are to be evaluated during the proof of intrinsic safety.
- Flame resistance acc. to IEC60332-1-2

Example of cable meeting above requirements: ÖLFLEX® EB CY from LAPP KABEL

Additional requirements if both channels (CH1, CH2) are laid in one cable:

- The test voltage wire-wire $\geq 1\,000\text{ V AC eff.}$
- The radial thickness of the insulation $\geq 0.2\text{ mm}$ (0.008").
- The conductor insulation shall withstand 500 V AC eff.

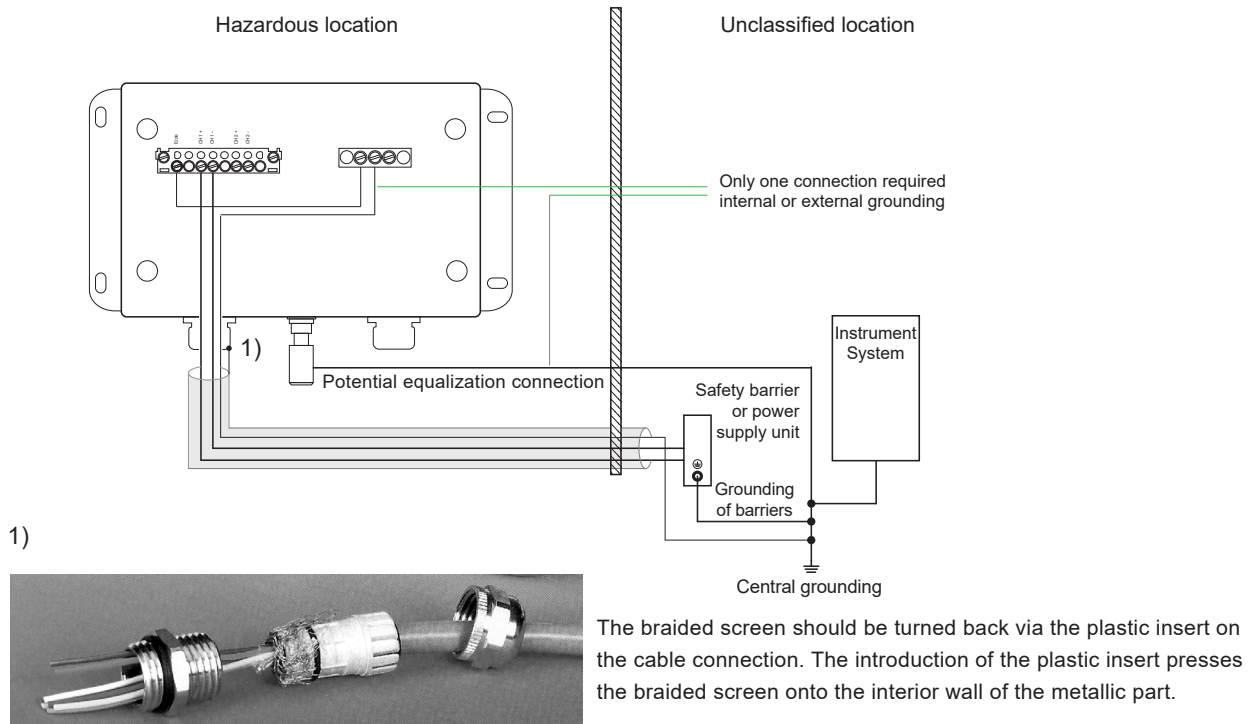

6.5 Calculation of the Maximum Cable Length

Intrinsically safe power supply device STAHL 9160/13-11-11 (order code HA011405)

Technical data for EE300Ex

Supply voltage: $U_{Bin} = 9\text{ V} + R_L \cdot 0.02\text{ A}$
 Max. current: $I_{out\ max} = 20\text{ mA}$

Technical data for STAHL 9160/13-11-11

Nominal operating voltage: $U_N = 24\text{ V}$
 Input voltage for transmitter: $U_S = 16\text{ V}$
 Max. load: $R_L = 600\text{ Ohm}$

Example: Calculation of maximum cable length

Cable 0.75 mm^2 (0.01 in²): $R_{cable} = 0.0267\ \Omega/\text{m}$
 Load resistor: $R_L = 200\ \Omega$
 Input voltage for transmitter: $V_S = 16\text{ V}$
 Min. supply voltage EE300Ex: $V_{Bmin} = 9\text{ V} + 200\ \Omega \cdot 0.02\text{ A} = 13\text{ V}$
 Maximum voltage drop on cable: $V_{cable} = V_S - V_{Bmin} = 16\text{ V} - 13\text{ V} = 3\text{ V}$
 Total cable resistance: $R_{cable\ total} = R_{cable} \cdot L_{total} \cdot 2$ (supply and return line)
 $V_{drop} = R_{cable\ total} \cdot I_{out\ max} =$
 $= R_{cable} \cdot L_{total} \cdot 2 \cdot I_{out\ max}$
 Transform in accordance with L_{total}
 $L_{total} = V_{drop} / (I_{out\ max} \cdot 2 \cdot R_{cable})$
 $L_{total} = 3\text{ V} / (0.02\text{ A} \cdot 2 \cdot 0.0267\ \Omega/\text{m})$
 $L_{total} = 2\ 800\text{ m maximum cable length}$

EX-SPECIFIC HINT OR WARNING

Attention: this is the maximum length without taking intrinsic safety into account. Cable capacitance and inductance can reduce the length.

6.6 Selecting a Suitable Intrinsically Safe Supply Unit for ATEX Zone Concept

This chapter provides an example for evidence of the intrinsic safety in accordance with EN 60079-14:2014, chapter 16.2.4 and EN 60079-25:2024, chapter 12.1. CH1 and CH2 are galvanically isolated. The proof of intrinsic safety shall be performed with appropriate equipment.

Example: Installation of the EE300Ex without display in Zone 0

Connection cable length: 300 m (984 ft)

Explosion group: IIC

Temperature class: T4

CH1 and CH2 connected by one single cable.

Intrinsically safe power supply device STAHL 9160/13-11-11 (please refer to chapter 8 Accessories)

(Extract from the EC-Type Examination Certificate)

Certified according to:

II 3 (1) G Ex nA nC [ja Ga] IIC T4 Gc (certificate number: DMT 03 ATEX E 010 X)

II (1) D [Ex ia Da] IIIC (certificate number: DMT 03 ATEX E 010 X)

Entity parameters:

$U_0 = 27 \text{ V}$

$I_0 = 88 \text{ mA}$

$P_0 = 576 \text{ mW}$

$C_0 \text{ IIC} = 90 \text{ nF}$

$C_0 \text{ IIB} = 705 \text{ nF}$

$L_0 \text{ IIC} = 2.3 \text{ mH}$

$L_0 \text{ IIB} = 17 \text{ mH}$

Technical data of the connection cable:

Cable type: ÖLFLEX® EB CY from Lapp Kabel

Cable cross-section: $4 \times 0.75 \text{ mm}^2$ ($4 \times 0.01 \text{ in}^2$)

Operating capacity: 110 nF/km

Inductivity: 0.65 mH/km

Cable capacity for 300 m (984 ft): $C_K = 0.3 \text{ km} * 110 \text{ nF/km} = 33 \text{ nF}$

Cable inductivity for 300 m (984 ft): $L_K = 0.3 \text{ km} * 0.65 \text{ mH/km} = 0.195 \text{ mH}$

Technical data for EE300Ex (extract from the EU-Type Examination Certificate):

Certified according to:

 II 1G Ex ia IIC T4 Ga

 II 1D Ex ia IIIC T₂₀₀ 80 °C Da

Entity parameters:

$U_i = 28 \text{ V}$

$I_i = 100 \text{ mA}$

$P_i = 700 \text{ mW}$

$C_i = 2.2 \text{ nF}$

$L_i = \text{negligibly small}$

Proof of the intrinsic safety according to EN 60079-11:2012,

EN 60079-25:2024 (Appendix A)

$U_0 = 27 \text{ V} \leq U_i = 28 \text{ V} \rightarrow \text{ok}$

$I_0 = 88 \text{ mA} \leq I_i = 100 \text{ mA} \rightarrow \text{ok}$

$P_0 = 576 \text{ mW} \leq P_i = 700 \text{ mW} \rightarrow \text{ok}$

$C_0 = 90 \text{ nF} \geq 2.2 \text{ nF} + 33 \text{ nF} \rightarrow \text{ok}$

$L_0 = 2.3 \text{ mH} \geq 0 \text{ mH} + 0.195 \text{ mH} \rightarrow \text{ok}$

Conclusion: The protection level of the intrinsically safe current circuit is met.

**Proof of the intrinsic safety according to EN 60079-11:2012,
EN 60079-25:2024 (Appendix A)**

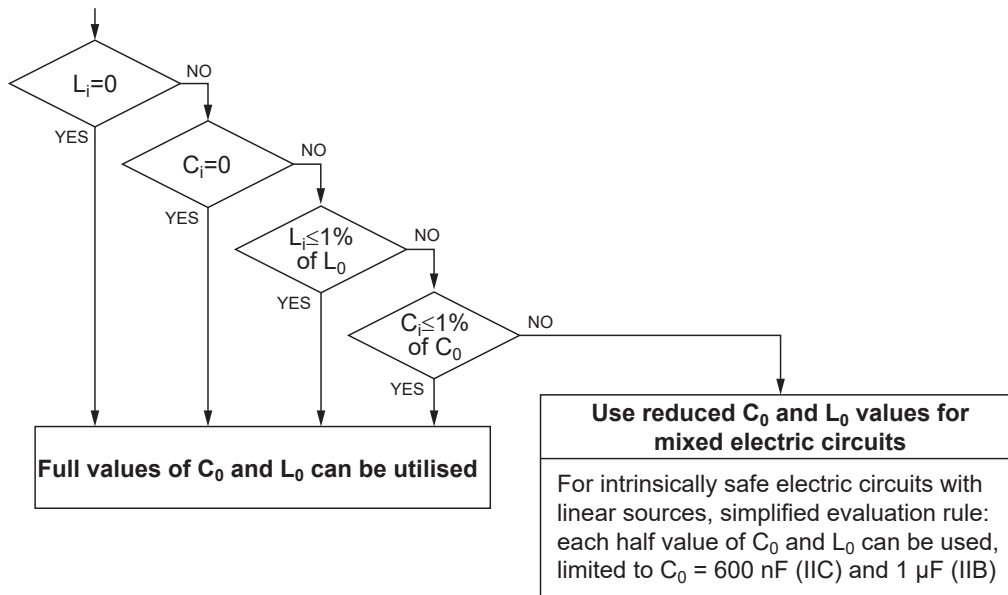

L_i = negligibly small \rightarrow no reduced C_0 and L_0 values are required.

6.7 Configuration Adapter

The on-board service interface is dedicated for the EE300Ex configuration and for the RH and T adjustment. This is done with a PC running the PCS10 Product Configuration Software, connected to the EE300Ex with the optional EE-PCA Product Configuration Adapter and HA011068 connection cable.

Please refer to [EE-PCA datasheet](#) and [HA011068 user manual](#). The PCS10 Product Configuration Software and the drivers are available for download free of charge at www.epluse.com/pcs10.

EX-SPECIFIC HINT OR WARNING

Configuration or adjustment of EE300Ex may not be performed in the hazard area.

EX-SPECIFIC HINT OR WARNING

CH1 and CH2 must be disconnected while using the EE-PCA Product Configuration Adapter.

EX-SPECIFIC HINT OR WARNING

When the front section has been removed from the hazard area, e.g. for calibration, the empty bottom section shall be protected against dirt and electrostatic charge with the blind front cover HA011401 (please refer to chapter 8 Accessories).

6.8 Calibration of the Current Loop

EX-SPECIFIC HINT OR WARNING

For the calibration of the current loop in explosion hazard areas only approved multimeters are permitted. During the measurement with these multimeters the requirements of the system description (the proof of intrinsic safety) shall be observed.

7 Maintenance and Service

EX-SPECIFIC HINT OR WARNING

It is essential that operation and maintenance in explosion hazard areas are only carried out by trained specialist staff who are authorised by the system operator.

EX-SPECIFIC HINT OR WARNING

Maintenance and repair work in explosion hazard areas must comply with the requirements of EN 60079-17 or IEC 60079-17, EN 60079-19 or IEC 60079-19 and with all the relevant national regulations.

7.1 Filter Cap Exchange

When employed in dusty, polluted environment, the filter cap shall be replaced once in a while with an E+E original one. A polluted filter cap causes longer response time.

EX-SPECIFIC HINT OR WARNING

When replacing a filter cap

- Ensure that the sensing element and filter cap do not touch each other.
For metal filter caps: ensure 0.5 mm distance between filter cap and sensing element.
- Do not touch the sensing elements.

7.2 Cleaning the EE300Ex Transmitter

7.2.1. Cleaning the Enclosure

EX-SPECIFIC HINT OR WARNING

Gently wipe the enclosure and the display with a soft damp cloth. Do not use detergents or abrasive substances.

7.2.2. Cleaning the Probe

If needed, the sensing head of the probe can be cleaned. For cleaning instructions, please refer to www.epluse.com/ee300ex.

EX-SPECIFIC HINT OR WARNING

When removing, reattaching or replacing a filter cap, ensure that the sensing element and filter cap do not touch each other! For metal filter caps: ensure 0.5 mm distance between filter cap and sensor element.

7.3 Configuration, Adjustment and Calibration

Refer to the data sheet EE-PCA Product Configuration Adapter and to the user manual HA011068 connection cable.

Definitions

Adjustment: the specimen is brought in line with the reference.

Calibration: the specimen is compared with a reference and its deviation from the reference is documented.

7.4 Error Messages on Display

| | |
|---------|--|
| Error 1 | RH sensing element damaged. Please contact the E+E Customer Service. |
| Error 2 | Condensation on the RH sensing element. Please contact the E+E Customer Service. |
| Error 3 | T sensing element damaged. Please contact the E+E Customer Service. |
| Error 4 | Short circuit at the T sensing element. Please contact the E+E Customer Service. |

7.5 Repairs

Repairs may be carried out by the manufacturer only. The attempt of unauthorised repair excludes any warranty claims.

8 Accessories

8.1 EE300Ex-M1 Humidity and Temperature Transmitter

| Description | Code |
|--|--------------------|
| Blind front cover for EE300Ex | HA011401 |
| Safety barrier, 1-channel, STAHL 9002/13-280-093-001 | HA011410 |
| Intrinsically safe supply unit, 1-channel, STAHL 9160/13-11-11 | HA011405 |
| Intrinsically safe supply unit , 2-channel, STAHL 9160/23-11-11 | HA011406 |
| Sealing plug for unused M16 cable glands | HA011402 |
| Sealing plug for unused M20 cable glands | HA011404 |
| Ball valve with 1/2" ISO female thread, ATEX certified | HA011403 |
| Intrinsically safe supply unit, 1-channel, PC MACX MCR-EX-SL-RPSSI-I | HA011411*) |
| Intrinsically safe supply unit, 2-channel, PC MACX MCR-EX-SL-RPSS-2I-2I | HA011412*) |
| O-ring 13x1.5 mm (0.5"x 0.06") - FKM-60 | HA050308 |
| PCS10 Product Configuration Software (Free download: www.epluse.com/pcs10) | PCS10 |
| Adapter Kit for configuration and adjustment (must be ordered together, see datasheet EE-PCA at www.epluse.com/ee-pca) Pos. 1: Product Configuration Adapter Pos. 2: Connection cable | EE-PCA HA011068 |

*) Only for ATEX and IECEx

8.2 EE300Ex-M3 Temperature Transmitter

| Description | Code |
|--|--------------------|
| Blind front cover for EE300Ex | HA011401 |
| Safety barrier, 1-channel, STAHL 9002/13-280-093-001 | HA011410 |
| Intrinsically safe supply unit, 1-channel, STAHL 9160/13-11-11 | HA011405 |
| Intrinsically safe supply unit , 2-channel, STAHL 9160/23-11-11 | HA011406 |
| Sealing plug for unused M16 cable glands | HA011402 |
| Sealing plug for unused M20 cable glands | HA011404 |
| Intrinsically safe supply unit, 1-channel, PC MACX MCR-EX-SL-RPSSI-I | HA011411*) |
| Intrinsically safe supply unit, 2-channel, PC MACX MCR-EX-SL-RPSS-2I-2I | HA011412*) |
| PCS10 Product Configuration Software (Free download: www.epluse.com/pcs10) | PCS10 |
| Adapter Kit for configuration and adjustment (must be ordered together, see datasheet EE-PCA at www.epluse.com/ee-pca) Pos. 1: Product Configuration Adapter Pos. 2: Connection cable | EE-PCA HA011068 |

*) Only for ATEX and IECEx

9 Technical Data

9.1 EE300Ex-M1 Humidity and Temperature Transmitter

Measurands

Relative Humidity (RH)

| | | |
|---|-----------------------------|--|
| Measuring range | 0...100 %RH | |
| Accuracy¹⁾ incl. hysteresis, non-linearity and repeatability | | |
| -15...+40 °C (5...104 °F) RH ≤90 % | ±(0.95 + 0.0013 * mv) %RH | |
| -15...+40 °C (5...104 °F) RH >90 % | ±1.8 %RH | |
| -25...+70 °C (-13...+158 °F) | ±(1.05 + 0.0084 * mv) %RH | |
| -40...+180 °C (-40...+356 °F) | ±(1.15 + 0.013 * mv) %RH | mv = measured value |
| Factory calibration uncertainty²⁾ | 0...90 %RH 90...100 %RH | ±(0.7 + 0.003 * mv) %RH ±1 %RH mv = measured value |
| Temperature dependency of electronics, typ. | 0.03 %RH/°C (0.017 %RH/°F) | |
| Response time t₉₀ with stainless steel filter at 20 °C (68 °F) | <30 s | |

1) Defined against E+E calibration reference.

2) Defined at 23 °C with a coverage factor factor k=2, corresponding to a confidence level of 95 %.

Temperature (T)

| | | |
|---|--|---|
| Measuring range¹⁾ | Wall mount Remote probe | -40...+60 °C (-40...+140 °F) -40...+180 °C (-40...+356 °F) |
| Accuracy²⁾ | <p>The graph plots accuracy (±ΔT [°C]) on the y-axis against temperature (T [°C]) on the x-axis. The y-axis ranges from 0 to 0.5 with increments of 0.1. The x-axis ranges from -40 to 180 with increments of 10. A shaded area represents the accuracy range, which starts at 0.24 at -40 °C, reaches a minimum of 0.1 at 20 °C, and rises to 0.47 at 180 °C. Dotted horizontal lines are drawn at 0.1, 0.24, and 0.47.</p> | |
| Factory calibration uncertainty³⁾ @23 °C (73 °F) | ±0.1 °C | |
| Temperature dependency of electronics, typ. | ±0.005 °C / °C | |

1) For TIIS (Japan): models T1, T7, T10: -40...+60 °C (-40...+140 °F).

2) Defined against E+E calibration reference. For model T1, the accuracy data is valid only for air speed higher than 0.2 m/s.

3) Defined at 23 °C with an coverage factor of k=2, corresponding to a confidence level of 95 %.

Calculated Quantities

| | | from | | up to | | | | unit | |
|-------------------------------|----|------|-------|------------|-----------|--------------|-----------|------------------|-----------------------|
| | | | | Wall Mount | | Remote Probe | | | |
| Dew point temperature | Td | -40 | (-40) | 60 | (140) | 100 | (212) | °C | (°F) |
| Frost point temperature | Tf | -40 | (-40) | 60 | (140) | 100 | (212) | °C | (°F) |
| Wet bulb temperature | Tw | -10 | (14) | 60 | (140) | 100 | (212) | °C | (°F) |
| Water vapour partial pressure | e | 0 | (0) | 200 | (3) | 1 100 | (15) | mbar | (psi) |
| Mixing ratio | r | 0 | (0) | 425 | (2 900) | 999 | (9 999) | g/kg | (gr/lb) |
| Absolute humidity | dv | 0 | (0) | 150 | (60) | 700 | (300) | g/m ³ | (gr/ft ³) |
| Specific enthalpy | h | 0 | (0) | 400 | (150 000) | 2 800 | (999 999) | kJ/kg | (BTU/lb) |
| Water activity | aw | 0 | | - | | 1 | | 1 | |
| Water content | x | 0 | | - | | 100 000 | | ppm | |

Outputs

Analogue

| | | | |
|---|---|-----------------------------------|--------------------------------|
| Two analogue outputs freely selectable and scalable | 2x 4 - 20 mA (2-wire) galvanically isolated Output 1 (CH1) must be connected! | $R_L (V_{CC}-9V) / 20 \text{ mA}$ | $R_L = \text{load resistance}$ |
| Accuracy @ 23 °C (68 °F) | ±0.06 % FS | | FS = full scale (20 mA) |
| Temperature dependency ¹⁾ | ±0.008 % FS/°C (±0.0044 % FS/°F) | | FS = full scale (20 mA) |

1) Deviating from 23 °C (68 °F), defined at 12 mA.

General

| | | | |
|---|---|---|--------------------------------|
| Supply Voltage | $V_{CC \text{ min}} = (9+R_L \cdot 0.02) \text{ V DC}$ | $V_{CC \text{ max}} = 28 \text{ V DC}$ | $R_L = \text{load resistance}$ |
| Current consumption, max. | 20 mA per channel | | |
| Electrical connection | Screw terminals max. 1.5 mm ² (AWG 16) | | |
| Cable glands | M16 M20 | Cable Ø5...10 mm (0.2...0.4") Cable Ø10...14 mm (0.4...0.6") | |
| Pressure range for pressure-tight probe | 0.01...20 bar (0.15...300 psi) | | |
| Working temperature range | Probe Electronics without display Electronics with display | According to measuring range -40...+60 °C (-40...+140 °F) -20...+60 °C (-4...+140 °F) | |
| Storage temperature range | Electronics and probe | -20...+60 °C (-4...+140 °F) | |
| Material | Enclosure Probe without Filter Probe cable | Stainless steel 1.4404 Stainless steel 1.4404 PFA (Perfluoralkoxy) | |
| Protection rating | Enclosure | IP65 / NEMA 4 | |
| Electromagnetic compatibility | EN 61326-1 FCC Part15 Class B | EN 61326-2-3 ICES-003 Class B | Industrial Environment |
| Conformity |  | | |

9.2 EE300Ex-M3 Temperature Transmitter

Measurand

Temperature (T)

| | | |
|---|--|---|
| Measuring range | Wall mount Remote probe | -40...+60 °C (-40...+140 °F) -70...+200 °C (-94...+392 °F) |
| Accuracy¹⁾ | | |
| Factory calibration uncertainty²⁾ @23 °C (73 °F) | | ±0.1 °C |
| Temperature dependence of electronics, typ. | | ±0.005 °C / °C |

1) Defined against E+E calibration reference. For model T1, the accuracy data is valid only for air speed higher than 0.2 m/s.

2) Defined at 23 °C with an coverage factor of k=2, corresponding to a confidence level of 95 %.

Output

Analogue

| | | | | |
|---|----------------------------------|----------|-----------------------------------|--------------------------------|
| Freely selectable and scalable analogue output | 4 - 20 mA | (2-wire) | $R_L (V_{CC}-9V) / 20 \text{ mA}$ | $R_L = \text{load resistance}$ |
| Accuracy @ 23 °C (68 °F) | ±0.06 % FS | | | FS = full scale (20 mA) |
| Temperature dependency¹⁾ | ±0.008 % FS/°C (±0.0044 % FS/°F) | | | FS = full scale (20 mA) |

1) Deviating from 23 °C (68 °F), defined at 12 mA.

General

| | | | |
|--|---|---|--------------------------------|
| Supply Voltage | $V_{CC \text{ min}} = (9+R_L \cdot 0.02) \text{ V DC}$ | $V_{CC \text{ max}} = 28 \text{ V DC}$ | $R_L = \text{load resistance}$ |
| Current consumption max. | 20 mA | | |
| Electrical connection | Screw terminals max. 1.5 mm ² (AWG 16) | | |
| Cable glands | M16 M20 | Cable Ø5...10 mm (0.2...0.4") Cable Ø10...14 mm (0.4...0.6") | |
| Pressure working range for remote probe with cut-in fitting | 0.01...20 bar (0.15...300 psi) | | |
| Working temperature range | Probe Electronics Electronics with display | Accordinging measuring range -40...+60 °C (-40...+140 °F) -20...+60 °C (-4...+140 °F) | |
| Storage temperature range | Electronics and probe | -20...+60 °C (-4...+140 °F) | |
| Material | Enclosure Temperature probe Probe cable | Stainless steel 1.4404 Stainless steel 1.4541 PFA (Perfluoralkoxy) | |
| Protection rating | Enclosure | IP65 / NEMA 4 | |
| Electromagnetic compatibility | EN 61326-1 FCC Part15 Class B | EN 61326-2-3 ICES-003 Class B | Industrial Environment |
| Conformity | | | |

9.3 Accuracy of E+E Humidity and Temperature Transmitters

The measurement accuracy depends both on the performance of the measuring instrument and on the correct installation in the application.

For best accuracy, every E+E RH and T transmitter is multi-point factory adjusted and calibrated in a highly stable RH / T reactor. Using a high-precision dew point mirror as reference, the overall uncertainty of the factory calibration U_{cal} is minimal.

The total measurement uncertainty U_{total} for E+E transmitters is calculated in accordance with EA-4/02 (European Accreditation, Evaluation of the Measurement Uncertainty in Calibration) and with GUM (Guide to the Expression of Uncertainty in Measurement) as follows:

$$U_{\text{total}} = k \cdot \sqrt{\left(\frac{U_{\text{cal}}}{2}\right)^2 + \left(\frac{U_{\text{accuracy}}}{\sqrt{3}}\right)^2}$$

| | |
|-----------------------|---|
| U_{total} | total accuracy incl. factory calibration |
| U_{cal} | uncertainty of the factory calibration |
| U_{accuracy} | accuracy of the measurement device |
| k | coverage factor k=2, corresponding to a confidence level of 95 %. |

For external calibrations, U_{total} is to be used as the evaluation criterion. The calculation does not include effects due to long-term drift or chemical exposure.

As National Metrological Institute (NMI) / Designated Institute (DI) responsible for maintaining National Standards in Austria, E+E Elektronik represents the highest level in calibration. For further details, please refer to www.eplusecal.com.

10 Conformity

10.1 Declaration of Conformity

E+E Elektronik Ges.m.b.H. hereby declares that the product complies with the respective regulations listed below:



European directives and standards.

Please refer to the product page at www.epluse.com/ee300ex for the Declarations of Conformity.

10.2 Electromagnetic Compatibility

EMC for industrial environment.

The transmitter is a group 1 device and corresponds to class B.

10.3 FCC Part 15 Compliance Statement

This equipment has been tested and found to comply with the limits for a Class B digital device, pursuant to part 15 of the FCC Rules. These limits are designed to provide reasonable protection against harmful interference in a residential installation. This equipment generates, uses and can radiate radio frequency energy and, if not installed and used in accordance with the installation manual, may cause harmful interference to radio communications. However, there is no guarantee that interference will not occur in a particular installation. If this equipment does cause harmful interference to radio or television reception, which can be determined by turning the equipment off and on, the user is encouraged to try to correct the interference by one or more of the following measures:

- Reorient or relocate the receiving antenna.
- Increase the separation between the equipment and receiver.
- Connect the equipment into an outlet on a circuit different from that to which the receiver is connected.
- Consult the dealer or an experienced radio/TV technician for help.

10.4 ICES-003 Compliance Statement

This Class B digital apparatus complies with Canadian ICES-003.

Cet appareil numérique de la classe B est conforme à la norme NMB-003 du Canada.

11 ATEX Certificate

(1) EU-Type Examination Certificate



Product Service

- (2) Equipment and Protective Systems Intended for Use in Potentially Explosive Atmospheres – **Directive 2014/34/EU**
- (3) EU-Type Examination Certificate Number:

TPS 13 ATEX 38892 003 X Issue 03



- (4) Equipment: Humidity / Temperature Transmitter
Type: EE300Ex with connection cable HA011068
- (5) Manufacturer: E+E Elektronik GmbH
- (6) Address: Langwiesen 7
4209 ENGERWITZDORF
AUSTRIA
- (7) This equipment and any acceptable variation thereto are specified in the schedule to this certificate and the documents therein referred to.
- (8) TÜV SÜD Product Service GmbH, notified body No. 0123 in accordance with Article 17 of the Council Directive 2014/34/EU of the European Parliament and of the Council dated 26 February 2014, certifies that this equipment has been found to comply with the Essential Health and Safety Requirements relating to the design and construction of equipment and protective systems intended for use in potentially explosive atmospheres, given in Annex II of the Directive. The examination and test results are recorded in the confidential reports 713215990.
- (9) Compliance with the Essential Health and Safety Requirements has been assured by compliance with:

EN IEC 60079-0:2018+A11:2024

EN 60079-11:2012

- (10) If the sign “X” is placed after the certificate number, it indicates that the equipment is subject to special conditions for safe use specified in the schedule to this certificate.
- (11) This EU-Type Examination Certificate relates only to the design and the construction of the specified equipment in accordance with Directive 2014/34/EU. Further requirements of this Directive apply to the manufacturer and supply of this equipment.
- (12) The marking of the equipment shall include the following:

Model without display: II 1G Ex ia IIC T4 Ga II 1D Ex ia IIIC T₂₀₀ 80 °C Da

Model with display: II 2G Ex ia IIC T4 Gb II 1G Ex ia IIB T4 Ga

Remote probe: II 1G Ex ia IIC T6...T1 Ga II 1D Ex ia IIIC T₂₀₀ 80 °C...220 °C Da

Certification body
Ridlerstraße 65, 80339 Munich

Munich, 2026-01-23

.....
Stefan Vierbücher

Page 1 / 4

EU-Type Examination Certificate without signature shall not be valid. The certificates may be circulated only without alteration. Extracts or alterations are subject to approval by TÜV SÜD Product Service GmbH.

In case of dispute, the German text shall prevail.

The document is internally administrated under the following number: EX5A 038892 0010 Rev.02

TÜV SÜD Product Service GmbH • Zertifizierstelle • Ridlerstraße 65 • 80339 München • Deutschland



Product Service

(13)

Schedule

(14) **EU-Type Examination Certificate TPS 13 ATEX 38892 003 X Issue 03**(15) Description of equipment:

The intrinsically safe devices EE300Ex-M1 (for the measurement of relative humidity (RH) and temperature (T)) and EE300Ex-M3 (temperature measurement only) are dedicated for the use in hazardous gas areas up to zone 0 and hazardous dust areas up to zone 20. With the EE300Ex-M1, the physical values dew point temperature (Td), frost point temperature (Tf), etc. can also be determined. Devices of this series can be operated as wall mount with fixed probe or with a remote probe, connected with a fixed cable.

The Humidity / Temperature Transmitter EE300Ex may only be supplied by an associated apparatus with intrinsically safe connectors. The intrinsically safe power supply and data output is carried out on an isolated 2-wire 4..20 mA interface. The device contains two galvanic isolated 2-wire channels, whereas channel 2 can only be operated together with channel 1.

Outside the hazardous area the configuration and adjustment of the EE300Ex can be performed with the associated HA011068 connection cable, a configuration device and a PC.

Technical data:

| Humidity / Temperature Transmitter EE300Ex | |
|--|---|
| Input voltage (Ui) | 28 V |
| Input power (Pi) | 700 mW (per channel, with linear source) |
| Input current (Ii) | 100 mA |
| Input capacitance (Ci) | 2,2 nF |
| Input inductance (Li) | negligible small |
| Ambient temperature electronics | $-40\text{ °C} \leq T_{\text{amb}} \leq +60\text{ °C}$ |
| Ambient temperature of combined humidity and temperature probe | $-40\text{ °C} \leq T_{\text{amb}} \leq +180\text{ °C}$ |
| Ambient temperature of temperature probe | $-70\text{ °C} \leq T_{\text{amb}} \leq +200\text{ °C}$ |
| Protection class | IP65 |

| Connection cable HA011068 | |
|----------------------------------|--|
| Maximum voltage (Um) | 250 VAC |
| Supply voltage | 5 VDC (USB) |
| Communication | USB or RS232 |
| Ambient temperature | $-40\text{ °C} \leq T_{\text{amb}} \leq +40\text{ °C}$ |
| Protection class | IP20 |

Page 2 / 4

EU-Type Examination Certificate without signature shall not be valid. The certificates may be circulated only without alteration. Extracts or alterations are subject to approval by TÜV SÜD Product Service GmbH.
In case of dispute, the German text shall prevail.

The document is internally administrated under the following number: EX5A 038892 0010 Rev.02

TÜV SÜD Product Service GmbH • Zertifizierstelle • Ridlerstraße 65 • 80339 München • Deutschland





Product Service

Application temperature of the probes:

Specification of the temperature class "TKG" for use in gas explosion hazardous areas and the temperature "TKD" for use in dust explosion hazardous areas depending on the ambient temperature "T_{amb}" with respect to the temperature and humidity probe.

| TKG | TKD | Humidity and Temperature Probe | TKD | Temperature Probe |
|-----|--------|-------------------------------------|--------|-------------------------------------|
| T6 | 80 °C | -40 °C ≤ T _{amb} ≤ +60 °C | 80 °C | -70 °C ≤ T _{amb} ≤ +60 °C |
| T5 | 95 °C | -40 °C ≤ T _{amb} ≤ +75 °C | 95 °C | -70 °C ≤ T _{amb} ≤ +75 °C |
| T4 | 130 °C | -40 °C ≤ T _{amb} ≤ +110 °C | 130 °C | -70 °C ≤ T _{amb} ≤ +110 °C |
| T3 | 195 °C | -40 °C ≤ T _{amb} ≤ +175 °C | 195 °C | -70 °C ≤ T _{amb} ≤ +175 °C |
| T2 | 200 °C | -40 °C ≤ T _{amb} ≤ +180 °C | 220 °C | -70 °C ≤ T _{amb} ≤ +200 °C |
| T1 | 200 °C | -40 °C ≤ T _{amb} ≤ +180 °C | 220 °C | -70 °C ≤ T _{amb} ≤ +200 °C |

Models:

| Model | |
|--|--|
| EE300Ex-M1: Measurement of relative humidity (RH) and temperature (T) EE300Ex-M3: Temperature measurement only | |
| T1 Wall mount with fixed probe | T7, T9, T10, T15, T22, T24 Remote probe with fixed cable The code number after the T stands for the probe type. |
|  |  |
| D0: without display D1: with display | D0: without display D1: with display |
| <i>Type of connection (measuring channels):</i> E13: Conduit Adapter (metal) E32: M12-Plug (plastic) E2, E15, E17, E18, E19, E20, E21, E22: cable gland (metal) | <i>Type of connection (measuring channels):</i> E13: Conduit Adapter (metal) E32: M12-Plug (plastic) E2, E15, E17, E18, E19, E20, E21, E22: cable gland (metal) |
| K0 | Kx: cable length [m]: 0,2 m to 10 m |
| Lx: probe length [mm]: 50 mm / 70 mm | Lx: probe length [mm]: 65 mm to 1000 mm |

(16) Test report: 713215990

Page 3 / 4

EU-Type Examination Certificate without signature shall not be valid. The certificates may be circulated only without alteration. Extracts or alterations are subject to approval by TÜV SÜD Product Service GmbH.
In case of dispute, the German text shall prevail.

The document is internally administrated under the following number: EX5A 038892 0010 Rev.02

TÜV SÜD Product Service GmbH • Zertifizierstelle • Ridlerstraße 65 • 80339 München • Deutschland



Product Service

(17) Special conditions for safe use:

- In dust explosive areas (IIIA, IIIB, IIIC) zone 20 and in gas explosive areas (IIC) with zone 0 the models with display and the models with M12 connections must not be used.
- The plastic filter caps must not be used in gas explosive areas of group IIC in zone 0.
- The sensor element must be covered with one of the provided filter caps.
- The sensor pipe of the remote probe is not electrically conductively connected with the housing of the main unit and must therefore be grounded separately. In addition, in potentially explosive areas of zone 0, the cable to the remote sensor must be installed in a metallic and earthed conduit.
- The configuration and adjustment of the EE300Ex is only permitted with the associated HA011068 connection cable outside the hazardous area. When the HA011068 is connected to the EE300Ex, CH1 and CH2 must not be connected.
- In case of optional use of the second measuring channel, both channels must be galvanically isolated from each other.

(18) Essential health and safety requirements:

met by standards

According to article 41 of Directive 2014/34/EU, EC-type examination certificates which have been issued according to Directive 94/9/EC prior to the date of coming into force of Directive 2014/34/EU (April 20, 2016) may be considered as if they have been issued already in compliance with Directive 2014/34/EU. By permission of the European Commission supplements to such EC-type examination certificates and new issues of such certificates may continue to hold the original certificate number issued before April 20, 2016.

This EU-type examination certificate according to Directive 2014/34/EU is a new issue of the EC-type examination certificate according to Directive 94/9/EC dated from 2013-03-05, including the 1st supplement dated from 2014-04-16, Issue 01 dated from 2019-09-30 and today's additional changes. Details are recorded in the confidential report 713215990.

Page 4 / 4

EU-Type Examination Certificate without signature shall not be valid. The certificates may be circulated only without alteration. Extracts or alterations are subject to approval by TÜV SÜD Product Service GmbH.

In case of dispute, the German text shall prevail.

The document is internally administrated under the following number: EX5A 038892 0010 Rev.02

TÜV SÜD Product Service GmbH • Zertifizierstelle • Ridlerstraße 65 • 80339 München • Deutschland

12 EU Declaration of Conformity



—
your partner
in sensor
technology.

CE - Declaration of Conformity

(According to ISO/IEC 17050-1)

| Product Types | From Version | Measurands | Output Signals |
|--|----------------------------------|--|----------------|
| EE300Ex-M1yyy EE300Ex-M3yyy yyy order code | 201107_1 201108_1 201115_1 | Humidity / Dewpoint Water activity Temperature | 4 - 20 mA |



CE 0123

E+E Elektronik Ges.m.b.H.
Langwiesen 7
4209 Engerwitzdorf / Austria

EU-TYPE-EXAMINATION CERTIFICATE:

TPS 13 ATEX 38892 003 X

| | | |
|--------------------------|----------------------------|---|
| EE300Ex without display: | II 1G Ex ia IIC T4 Ga | II 1D Ex ia IIIC T ₂₀₀ 80°C Da |
| EE300Ex with display: | II 2G Ex ia IIC T4 Gb | II 1G Ex ia IIB T4 Ga |
| EE300Ex remote probe: | II 1G Ex ia IIC T6...T1 Ga | II 1D Ex ia IIIC T ₂₀₀ 80°C...220°C Da |

The EU-Type-Examination was issued by TÜV SÜD Product Service GmbH (notified body No 0123),
Ridlerstraße 65, 80339 München / Germany.

We declare under our sole responsibility that this product(s) (see product table above) corresponds to the following regulations and their subsequent modifications:

| Directive Reference | Directive Area |
|----------------------------|---|
| 2014/30/EU | Electromagnetic compatibility |
| 2014/34/EU | Equipment and protective systems in potentially explosive atmospheres |
| 2011/65/EU and 2015/863/EU | RoHS |

The products comply with the following standards or standardized documents:

| Standards | Year of Ratification | Standards | Year of Ratification |
|----------------|----------------------|------------------|----------------------|
| EN IEC 60079-0 | 2018+A11:2024 | EN 61326-1 | 2013 |
| EN 60079-11 | 2012 | EN IEC 61326-1 | 2021 |
| EN IEC 63000 | 2018 | EN 61326-2-3 | 2013 |
| | | EN IEC 61326-2-3 | 2021 |

Designed for use in industrial environment. Affixing of the CE marking (for the first time): 2013

Test Report: Conformity_EE300Ex_06.docx

Modification: Update EMC standards

Dr. Wolfgang Pucher
(Managing Director)

Engerwitzdorf, June 30th, 2025

Martin Birkbauer
(Development Sensors)

File: Declaration of conformity EE300Ex_07.docx

13 IECEx Certification of Conformity - COC

For more information see www.iecex.com/
or our website www.epluse.com/ee300ex.

14 Certificates China, Korea and Japan

For more information please contact the E+E sales support.

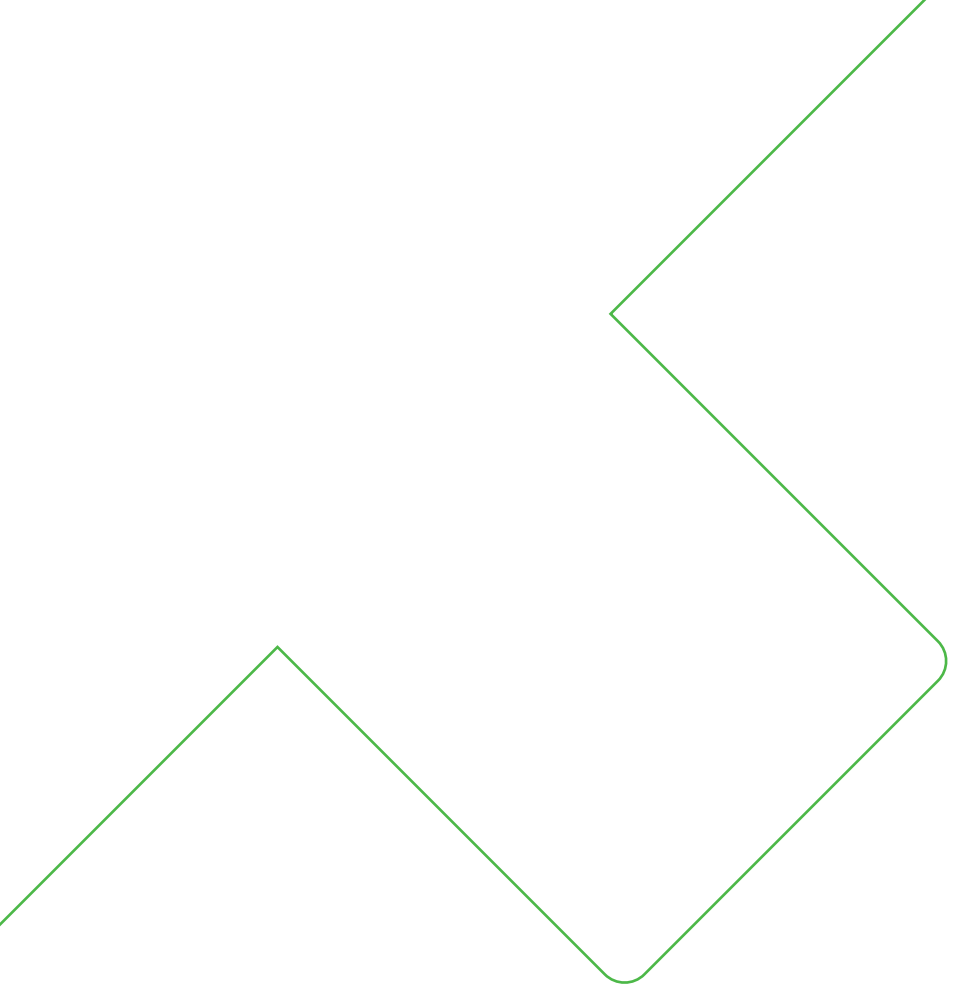

Company Headquarters &
Production Site

E+E Elektronik Ges.m.b.H.
Langwiesen 7
4209 Engerwitzdorf | Austria
T +43 7235 605-0
F +43 7235 605-8
info@epluse.com
www.epluse.com

Subsidiaries

E+E Sensor Technology (Shanghai) Co., Ltd.
T +86 21 6117 6129
info@epluse.cn

E+E Elektronik France SARL
T +33 4 74 72 35 82
info.fr@epluse.com

E+E Elektronik Deutschland GmbH
T +49 6171 69411-0
info.de@epluse.com

E+E Elektronik India Private Limited
T +91 990 440 5400
info.in@epluse.com

E+E Elektronik Italia S.r.l.
T +39 02 2707 86 36
info.it@epluse.com

E+E Elektronik Korea Ltd.
T +82 31 732 6050
info.kr@epluse.com

E+E Elektronik Corporation
T +1 847 490 0520
info.us@epluse.com



—
your partner
in sensor
technology.