

WindObserver™ 70

WindObserver™ 75

GILL

User Manual

Ultrasonic Anemometer

(Parts 1390-70-B-XXX and 1390-75-B-XXX)

Doc No: 1390-PS-0038

Issue 6 (Applies to firmware 2387 6.04 onwards).



Gill Instruments Limited
Saltmarsh Park, 67 Gosport Street, Lymington,
Hampshire, SO41 9EG, UK
Tel: +44 1590 613500, Fax: +44 1590 613555
Email: anem@gillinstruments.com Website: www.gillinstruments.com

Contents

1.	FOREWARD	5
2.	INTRODUCTION.....	5
3.	FAST TRACK SET-UP	5
4.	SPECIFICATION	6
5.	PRE-INSTALLATION	7
5.1.	Equipment supplied	7
5.1.1	WindObserver 70/75 Part Numbers.	7
5.2.	Packaging.....	7
5.3.	Installation requirements.....	8
5.4.	Connector and Cable Assembly.....	9
6.	INSTALLATION.....	11
6.1.	Installation Guidelines.....	11
6.2.	Bench system test	12
6.3.	Cabling	12
6.4.	Power supplies	13
6.5.	Connections.....	14
	Default Settings.....	16
	Connecting to a PC with a RS422 or RS485 input	16
	Networking units.....	17
6.6.	Indoor Power and Communications Interface (Part 1189-PK-021).....	18
	Connecting to a PCI Unit with RS422 input.....	18
	PCI Electrical Power Requirements	18
	PCI Connector Pin and Cable assignments	19
	Anemometer connector – 15 way skt.....	19
	Auxiliary Analogue Outputs – 9 way (Not Applicable).....	19
	DC Supply – 4 way.....	19
	RS 232 Output – 9 way Skt	19
	RS422 Network In – 9 way Skt	20
	RS422 Network Out – 9 way Plg.....	20
6.7.	Using the WindObserver 70/75 with the Gill WindDisplay	21
6.8.	Mechanical installation.....	25
	Location	25
	Orientation	25
	Mounting (Short and Long Mounts).....	25
	Pipe Mounting (use with Pipe Mount).....	27
	Custom Mount (Use with WindObserver No Mount Option).....	27
	Alignment.....	28
	Figure 2a North Marker (Long Base Mount shown for illustrative purposes).	28
	Figures 2b WindObserver 70/75 Outline Dimensions with Mounts.....	29
7.	MESSAGE FORMATS & OPTIONS.....	31
7.1.	Wind Speed format	31
7.2.	Output formats.....	31
	Low wind speeds.....	31
7.3.	Networking.....	32
7.4.	Units	33
7.5.	Output rate.....	33
	Sample Average.....	33
7.6.	Averaging (Digital Data).....	33
	7.6.1 G Command Averaging.	33

7.6.2	Modes 14 and 15 Road Weather Averaging (RWA).....	34
7.7.	Heating Option.....	37
7.8.	45° Offset.....	37
7.9.	Vertical Output Padding.....	37
7.10.	ASCII message format (UV and Polar)	38
	ASCII UV format.....	38
	ASCII Polar format	39
	ASCII Polled (UV and Polar).....	39
7.11.	NMEA Format.....	40
8.	CONFIGURING.....	42
8.1.	Configuring using HyperTerminal.....	42
8.2.	Entering Configuration mode	42
8.3.	Returning to Measurement mode.....	43
8.4.	Checking the configuration	43
8.5.	Changing settings.....	43
8.6.	Configuration Settings.....	44
	Ax – Not Applicable	44
	Bx - Baud Rate.....	44
	Cx- Not applicable.....	44
	Dx- Diagnostic and Configuration Command (see also Section 10.6).....	44
	Ex - Full Duplex/Half Duplex Mode	45
	Fx- Data and Parity Options	45
	Gx to Gxxxx - Averaging (Digital Outputs only)	45
	Hx - Heating.....	45
	Jx - Not applicable.....	45
	Kx – NMEA Settings.....	45
	Lx - ASCII Message Terminator.....	45
	Mx to Mxx - Message Format	46
	Nx – Unit Identifier Address	46
	Ox – ASCII Output Format (Output String Padding).....	46
	Px - Output Rate	46
	Q- Measurement Mode.....	46
	Tx - Not Applicable.....	47
	Ux – Digital Output Units	47
	Vx- Vertical Output Padding	47
	Xx - 45° Alignment Offset/Inverted Operation.....	47
	Yx – Not Applicable.....	47
	Zx – Not Applicable.....	47
9.	VIEW AND LOG DATA WITH WINDVIEW SOFTWARE	48
10.	MAINTENANCE & FAULT-FINDING	53
10.1.	Cleaning and Handling.....	53
10.2.	Servicing.....	53
10.3.	Fault-finding.....	53
10.4.	Safe Mode	54
10.5.	Status (error) codes	55
10.6.	Bench test.....	56
	Use of an Integrity Check Chamber (Optional Item)	56
10.7.	Returning units.....	57
11.	APPENDICES.....	58
11.1.	Glossary & Abbreviations.....	58
11.2.	Guarantee.....	59
11.3.	Principle of operation	60

11.4. Electrical Conformity..... 61

1. FOREWARD

Thank you for purchasing the WindObserver 70/75 manufactured by Gill Instruments Ltd. The unit has no customer serviceable parts and requires no calibration or maintenance. To achieve optimum performance we recommend that you read the whole of this manual before proceeding with use. Do **NOT** remove black “rubber” transducer caps.

Gill products are in continuous development and therefore specifications may be subject to change and design improvements without prior notice.

The information contained in this manual remains the property of Gill Instruments and should not be copied or reproduced for commercial gain.

2. INTRODUCTION

The WindObserver 70/75 wind sensor is a very robust unit with no moving parts, outputting wind speed and direction. The units of wind speed, output rate and formats are all user selectable.

The WindObserver 70/75 is available with optional enhanced de-icing heating (recommended if severe icing is likely).

The WindObserver 70/75 can be used in conjunction with a PC, data logger or other device, provided it is compatible with the RS422 output. Multiple units can be networked if required.

Alternatively, the WindObserver 70/75 is designed to connect directly to the Gill WindDisplay unit to provide a complete wind speed direction system.

The output message format can be configured in Polar, UV (2-axis), NMEA (0183 Version 3), Tunnel formats, and as either a Continuous output or Polled (requested by host system), detailed in full in Section 8 Message Formats & Options.

3. FAST TRACK SET-UP

If you are in a hurry to try out the WindObserver 70/75, are familiar with Gill equipment, and coupling to a PC using RS422, go to the following sections:

Section 6 Installation

Section 7 Message Formats & Options

Section 8 Configuring

After you have successfully set up the WindObserver 70/75, we strongly advise that you then go back and read the rest of the manual to ensure that you get the best results from the WindObserver 70/75.

4. SPECIFICATION

Measurement

Output	1, 2, 4 Hz
Parameters	UV, Polar, NMEA
Units	m/s, Knots, MPH, KPH ft/min
Averaging	Flexible 1-3600 seconds or Adjustable Averaging for Road Weather applications

Wind Speed

Range	0 - 70m/s (WindObserver 70) or 0 - 75m/s (WindObserver 75)
Accuracy	±2% @ 12m/s
Resolution	0.01m/s
Offset	±0.01m/s

Direction

Range	0 - 359°
Accuracy	± 2°
Resolution	1°

Anemometer Status

Supplied as part of standard message

Starting Threshold

0.01 m/s

Dead Band Wind Direction

None

Power Requirement

Anemometer only	9-30 V DC 50mA average, reverse voltage protected
Heating - Optional	Allow for 7A @ 24v AC rms ± 15%, or 24v DC± 10%.

Digital Output

Communication	RS422, full duplex, network facility
Baud rates	1200, 2400, 4800, 9600, 19200, 38400
Formats	8 data, odd, even or no parity

Dimensions

Size	See Manual Figure 2b drawings for dimensions	
Weight	WindObserver 70/75	1.34kg (no mount or lead)
	Base Mount Short	0.63kg.
	Base Mount Long	1.05kg.
	Pipe Mount	1.06kg.

Materials

External Construction	Stainless Steel 316
-----------------------	---------------------

Environmental

Moisture protection	IP66 (NEMA4X)
Operating temperature	-55°C to +70°C, heating on
Humidity	0% to 100% RH
Precipitation	300mm/hr, Mil Std 810f Method 506.4
EMC	EN 61326-1 EN 60945

Icing MIL STD 810F Method 521.1 Procedure 1

Standards

Traceable to UK national standards

Site Calibration

Lloyds Register Type Approved
None required. (See Section 10.6 Zero Wind Check)

WARNING NOTE:-



When heating is activated the bullet and transducer arms will get very hot and should not be handled.

5. PRE-INSTALLATION

5.1. Equipment supplied

- WindObserver 70/75.
- and Installation kit 1390-10-163 (see para 5.4).
- and WindObserver 70/75 User Manual on a CD (this manual).

5.1.1 WindObserver 70/75 Part Numbers.

Available parts are as detailed below:-

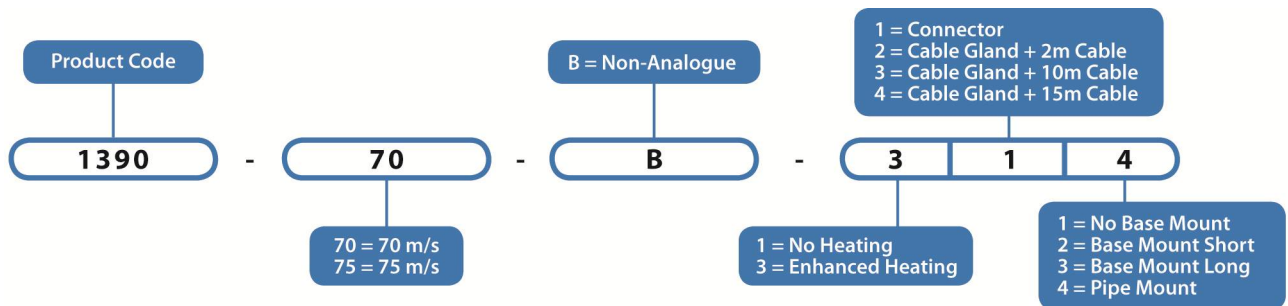

Optional Extras:

Item	Part Number
Cable 3 Pair twisted and Shielded wires, 24awg, per metre.	026-02660
Cable 4 Pair twisted and Shielded wires, 24awg, per metre.	026-03156
Cable 9 Pair twisted and Shielded wires, 22awg, per metre.	026-02663
Integrity Check Chamber	1277-00-052
19 way Connector kit	1390-10-163
Base Mount Short	1390-30-154
Base Mount Long	1390-30-155
Pipe Mount	1390-30-156

5.2. Packaging

Whilst the WindObserver 70/75 is being moved to its installation site, the unit should be kept in its packaging. Retain the packaging for use if the unit has to be moved or returned to Gill Instruments.

5.3. Installation requirements

Host system - One of the following:

- PC with an internal or external interface compatible with the RS422 output from the WindObserver 70/75.
- Gill WindDisplay.
- Other equipment with I/O compatibility to the WindObserver 70/75.
For example if the unit has Digital outputs, a Data Logger, Chart Recorder, or PC.
- Networking - Multiple WindObserver 70/75 units can be networked

Software - One of the following:

- Gill Wind Software used as a Terminal program only (Wizard and Sync Comms not applicable). Wind will run on PC's up to and including Windows 10 and can be downloaded free from:- <http://www.gillinstruments.com/main/software.html>
- HyperTerminal (supplied with Windows™ 9x to XP).
- Other Terminal Emulation software packages.

Cable and Junction box

To connect between the WindObserver 70/75 and the host system. The unit is supplied with a base mounted connector system or flying cable options (requiring a mast mounted junction box (not provided)) for onward connection.

If using a flying cable option it must be retained with a cable tie within 150mm of the base of the anemometer.

Mounting Bracket

The WindObserver 70/75 can be supplied with a short or long base mount to use with a mounting bracket (not provided). The WindObserver 70/75 can be attached to the bracket via the four tapped holes in the base mount fitted to the unit. Always ensure that the gasket supplied is fitted to the base of the anemometer mount.

It is important that the gasket supplied forms a watertight seal on the base of the anemometer.

In the event that the mounting bracket supplied by the customer is not flat or does not form complete support for the anemometer base; the customer must fit a mounting ring as shown in Figure 2.

Mounting Pole

The WindObserver 70/75 can be supplied with a pole mount that provides the option to attach to a pole with or without a thread (pole not provided). The WindObserver 70/75 can be retained to the pole via the three tapped holes in the pole mount fitted to the unit.

5.4. Connector and Cable Assembly.

The WindObserver 70/75 variant with a connector base is supplied with a mating 19 way connector.

Open the pack of connector parts supplied (Gill Part 1390-10-163).

A set of assembly instructions are supplied with the connector together with:-

Table of Equivalent Part Numbers		
Part Name	Gill Part No.	Cannon Trident Part No.
Connector head, 19 way	020-04464	192993-0054
Metal backshell (7 pieces)	020-04465	192993-0084
Solder bucket contacts (5 per pack, (4 –off packs))	020-04469	192900-0635

Arrange Backshell (Gill Part Number 020-04465).

Pass parts 1-6 along the cable as per the diagram below.

(Note that the connector supplies the correct strain relief for cables with an outside diameter of 7.9 to 12.6mm).

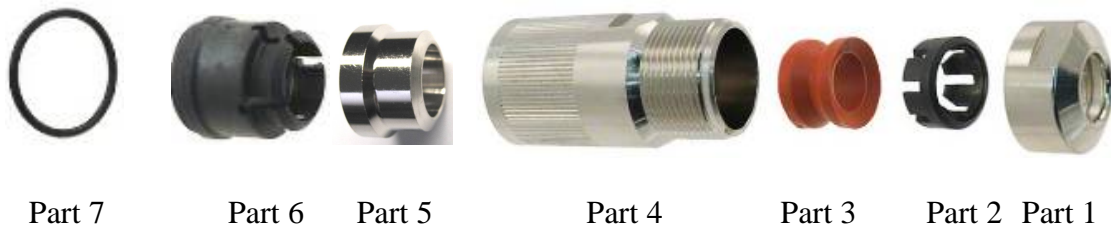

Prepare Cable (e.g. Gill Part 026-02663).

Trim back the cable outer and twisted pair screen sleeves 40mm (see diagram below).

Trim back the screen drain wires to a length of 24mm.

Strip back the connection wires by 7.1mm and tin solder.

Solder the wires to the bucket contacts (will take 14awg to 26awg wire).

Unused wires should be cut back and insulated.

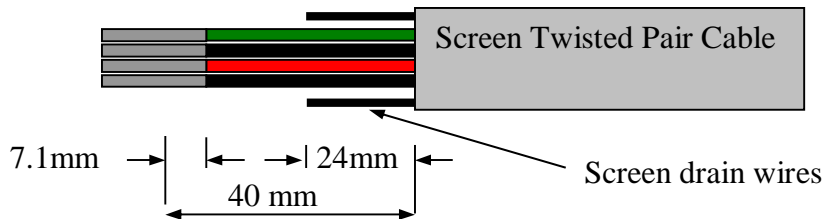

Prepare Connector Head (Gill Part 020-04464).

Remove the connector thread protector and place the O-ring (part 7) into the groove of the connector head (020-04464).

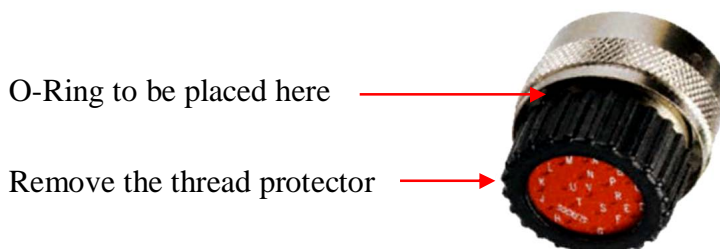

Assemble Connector to the Cable.

Referring to Page 9 and page 15 push connector contacts through the red connector head seal into the appropriate location, when in place there should be a click as the contact locks into position.

Once contacts are in position pass part 6 up the cable and into position as shown below.

Note: if a connector pin needs removing use Cannon Extraction Tool, Manufacturer's Part 192922-1450.

Fold and spread screen wires over part 6 and then push up part 5 as shown to clamp screen wires between Parts 5 and 6.



Now screw in part 4 and torque up to a value of 10Nm.

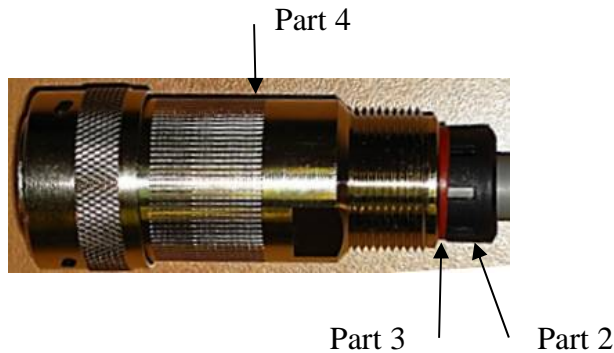

Pass parts 3 and 2, the cable seal and cable grip from the connector kit, along the cable to the housing.

Now screw in item 1, the clamp nut, over parts 2 and 3 and onto the housing and torque up to a value of 10Nm.



6. INSTALLATION

Do NOT remove the black “rubber” transducer caps. Warranty is void if the Red security seal is damaged or removed.

Take care not to knock the four Transducer arms. All the time the WindObserver 70/75 is not in its final location, it should be protected from damage by keeping it in the original packaging as long as possible, treating it as a delicate instrument.

If an Intrinsically Safe (IS) device is required, the I.S. WindObserver must be used - the WindObserver 70/75 is NOT an IS device.

6.1. Installation Guidelines

The WindObserver 70/75 has been designed to meet and exceed the stringent standards listed in its specification. Operating in diverse environments all over the world, WindObserver 70/75 requires no calibration or adjustment whatsoever.

As with any sophisticated electronics, good engineering practice should be followed to ensure correct operation.

- Always check the installation to ensure the WindObserver 70/75 is not affected by other equipment operating locally, which may not conform to current standards, e.g. radio/radar transmitters, boat engines, generators etc.

Guidelines –

- Avoid mounting in the plane of any radar scanner – a vertical separation of at least 2m should be achieved.
- Radio transmitting antennas, the following minimum separations (all round) are suggested.
 - VHF IMM – 1m
 - MF/HF – 5m
 - Satcom – 5m (avoid likely lines of sight)
- Ensure the product is correctly earthed in accordance with this manual.
- Use cables recommended by Gill, keeping the length below the maximum allowed (*See Section 6.3*) Where the cables are cut and re-connected (junction boxes, plugs and sockets) the cable screen integrity must be maintained, to prevent the EMC performance being compromised.
- Earth loops should not be created – earth the system in accordance with the installation guidelines. (*See Section 6.5*)
- Ensure the power supply operates to the WindObserver 70/75 specification at all times.

Avoid turbulence caused by surrounding structures that will affect the accuracy of the WindObserver 70/75 such as trees, masts and buildings. The World Meteorological Organisation makes the following recommendation:

- The standard exposure of wind instruments over level open terrain is 10m above the ground. Open terrain is defined as an area where the distance between the sensor and any obstruction is at least 10 times the height of the obstruction.

When installing the unit degrease the unit and hold with lint free gloves to reduce the build-up of deposits.

6.2. Bench system test

Note: Prior to physically mounting the WindObserver 70/75 in its final location, we strongly recommend that a bench system test be carried out to confirm the system is configured correctly, is fully functional and electrically compatible with the selected host system and cabling (preferably utilising the final cable length). The required data format, units, output rate, and other options should also all be configured at this stage. If an Integrity Check Chamber (ICC) has been purchased refer to Section 10.6.

6.3. Cabling

Cable type

An RS422 compatible cable should be used, with the number of twisted pairs matching the application.

Generic description – Twisted pairs with drain wire, screened with aluminised tape, with an overall PVC sheath. E.g. wire size 7/0.2mm (24 AWG)

The table shows some suitable manufacturers' references; other manufacturer's equivalents can be used.

Table 1

No. of Pairs	Gill ref.	Belden ref.	Batt electronics ref.	Cable Gauge
2	-	9729	91071	24
3	026-02660	9730	91030	24
4	026-03156	9728	91199	24
6	-	8778	91011	22
9	026-02663	8774	91009	22

Cable length

The typical maximum length at 9600 baud is 1km (3200ft), using the recommended cable. If any problems of data corruption are experienced (due to, for example, a high local electrical 'noise' level), then a lower baud rate should be used. Alternatively, a thicker or higher specification cable can be tried. If longer cables are used than supplied then consideration should be given to powering the Heater using lower gauge wire or paralleling wires to avoid volt drops.

Cabling and junction box

If the WindObserver 70/75 unit is fitted with a flying 9 pair cable attached, this must be terminated in a suitable terminal box to IP66 or better, fitted with glands to prevent moisture ingress.

The cable type from the terminal box to the host system must be as specified above. If any cable is likely to be exposed to mechanical damage, it must be enclosed in a suitable conduit or cable tray. The cable must be securely fixed with cable clamps or equivalent at regular intervals such that the WindObserver 70/75 cable gland does not support the cable weight.

For units with a cable gland at the base of the WindObserver 70/75 it **should not** be directly exposed to moisture, as the anemometer is vented to air at the base to avoid pressure build up. If an IP66 rating is essential or the unit is mounted other than 'right way up' **use the gasket** provided in the mounting kit and apply additional sealing compound around the base.

6.4. Power supplies

WindObserver 70/75 units

Sensor Supply: -

Voltage	9v to 30v DC
Current	50mA average, 60mA max.

- The WindObserver 70/75 has reverse polarity protection.

WindObserver 70/75 Heating Option

Heater Supply: -

Voltage	24V \pm 15% AC RMS or 24V DC \pm 10%.
Current	allow for 7A.

- **The AC Supply must be isolated from Mains Supply.**
- The heating module requires a separate power supply.
- Heater Cable length should be minimised to avoid cable volt drops and ensure maximum voltage received at the Anemometer.
- All three heater pair cables must be used, connect yellow, brown and orange wires to heater positive and their respective black wires to heater negative.
- The heating (H command) is H2 as a default condition. If heating is not required enabled then the H command must be set for H1.

The WindObserver 70/75 has reverse polarity protection.

WARNING NOTE:-



When heating is activated the bullet and transducer arms will get very hot and should not be handled.

6.5. Connections

Important: Any cable wires not used should be isolated and grounded at the terminating equipment/user end.

Do NOT connect the unit's 0V, heating –ve, or digital 0V to the screen or earth.

On units with integral cable the screens of each pair are joined together inside the anemometer - these should be joined to the cable screen(s) of any further cable run.

Avoid long grounding loops. Digital 0V should be used in conjunction with RS422 TX RX lines in order to improve noise immunity.

Earthing or grounding

To ensure correct operation, and for maximum protection against lightning, the anemometer **MUST** be correctly earthed (grounded) via its mountings. Inadequate Earthing will degrade anemometer performance, particularly in the presence of radio frequency interference.

See Fig 1 Suggested mounting bracket and Earthing (grounding) arrangements

The unit **MUST** be connected to an appropriate grounding point with a minimum of 6mm² copper wire, via the M5 base screws. The cable screens must be joined with any cable screen continuing from the unit's cable via a junction box. The primary earth for the anemometer must be provided via the base screws and not via the cable screens.

View of the WindObserver 70/75 base connector variant

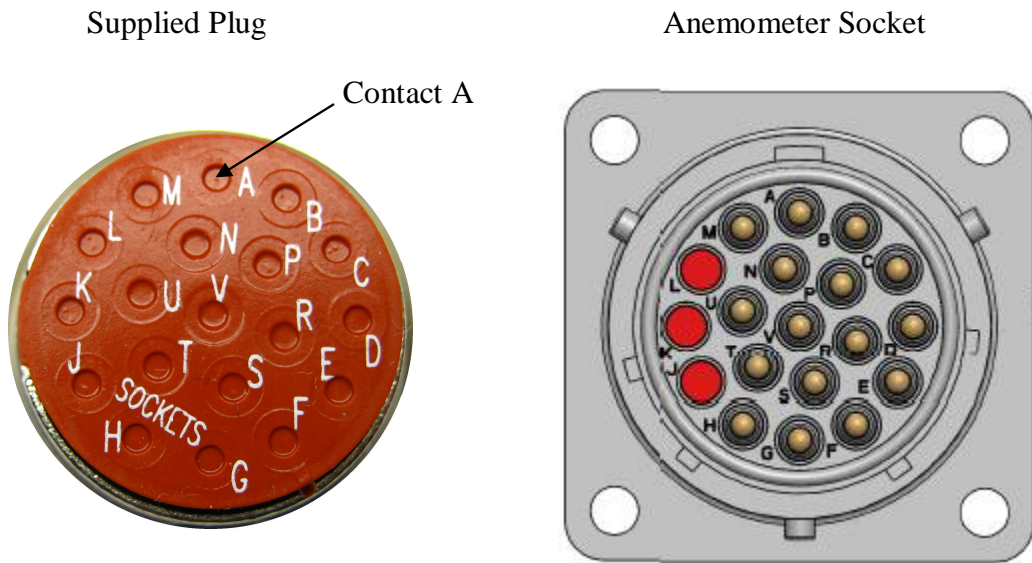

Table 2 - 19 way connector and cable connections

19 Way Connector Terminal Letter	Cable Gland Option		Signal Designation
	Conductor	Colour	
P	Pair 1	Green	RS422 TXB (+)
C	Pair 1	Black	RS422 TXA (-)
U	Pair 2	White	RS422 RXB (+)
V	Pair 2	Black	RS422 (RXA (-)
R	Pair 3	Red	Supply V+
D	Pair 3	Black	Supply V -
M	Pair 4	Blue	Digital 0v
N	Pair 4	Black	Not Used (Isolate)
A	Pair 5	Yellow	Heater +
B	Pair 5	Black	Heater -
H	Pair 6	Brown	Heater +
G	Pair 6	Black	Heater -
E	Pair 7	Orange	Heater +
F	Pair 7	Black	Heater -
T No Connection	Pair 8	White	Not Used (Isolate)
S No Connection	Pair 8	Red	Not Used (Isolate)
L No Connection	Pair 9	Green	Not Used (Isolate)
K No Connection	Pair 9	Red	Not Used (Isolate)
J No Connection	Not Applicable	Not Applicable	Not Used

Default Settings

The factory default settings are:

Unheated Unit.

A0 B3 C1 E1 F1 G0000 J1 K1 L1 M2 NA O1 P1 T1 U1 V1 X1 Y1 Z1

Heated Unit.

A0 B3 C1 E1 F1 G0000 H2 J1 K1 L1 M2 NA O1 P1 T1 U1 V1 X1 Y1 Z1

Note that the Heating (H Command) is enabled as a default condition. If heating is not required then the H command must be set for H1.

See Section 8 Configuring for further details.

Connecting to a PC with a RS422 or RS485 input

The PC requires either an internal RS422 interface card, or an external RS422/485 to RS232 or USB converter, to plug into the PC or host equipment.

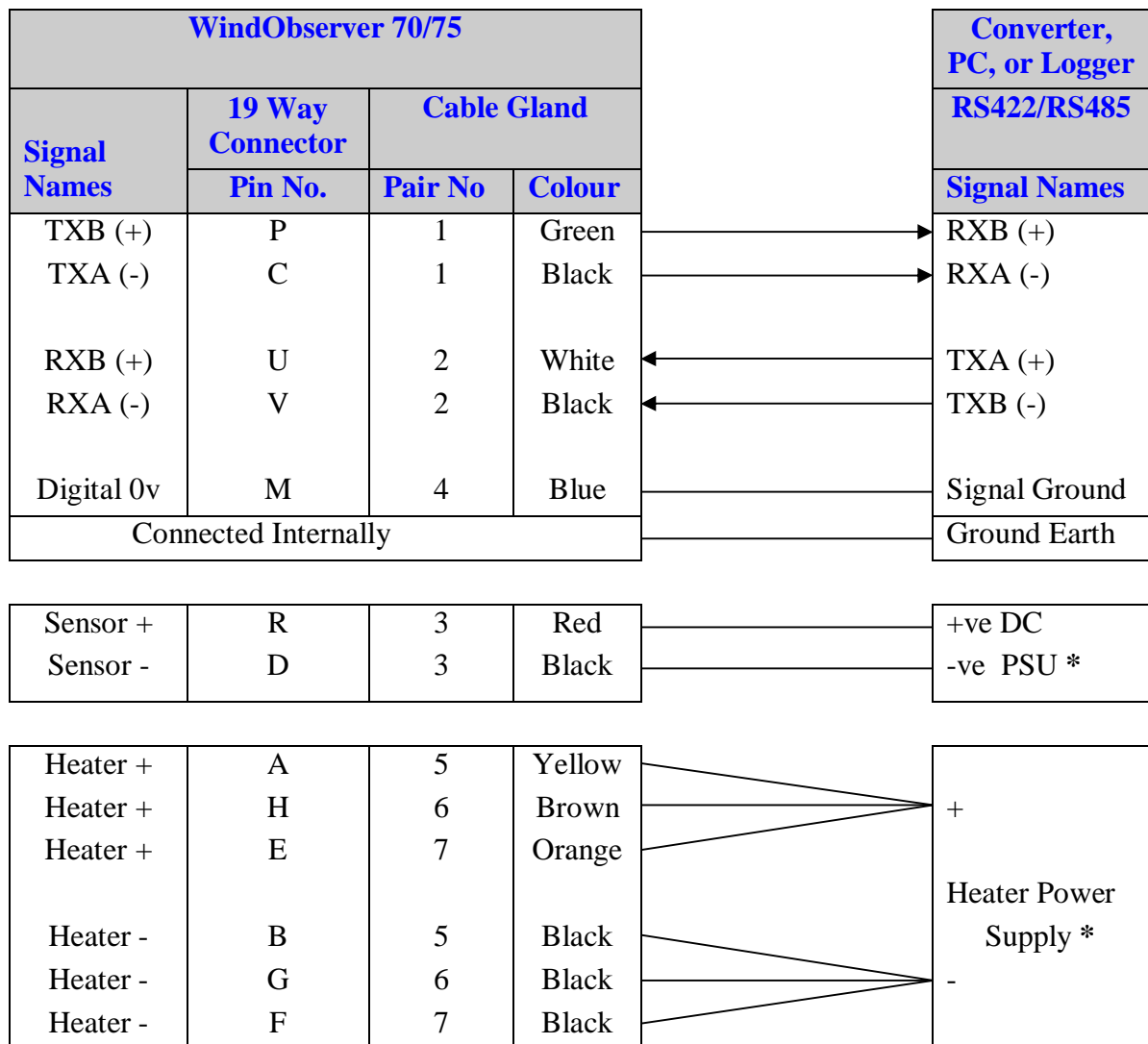

*...For Power Supply Information see Section 6.4.

Note:-

The 3 heater +ve wires should be connected in Parallel, as too should the return 3 Heater -ve wires.

Networking units

Before coupling units into a network:

- Each device must be configured with a unique Unit Identifier (letter A to Z) however in multi drop systems it could be advised to avoid using letters A-F, K,M,N and P as they could appear in the data string.
- Unit must be set for half duplex mode (E2 setting) see Para 7.3).
- It must be configured to a tri-state polled mode [M3](#) or [M4](#).

See also Section 8 – Configuring

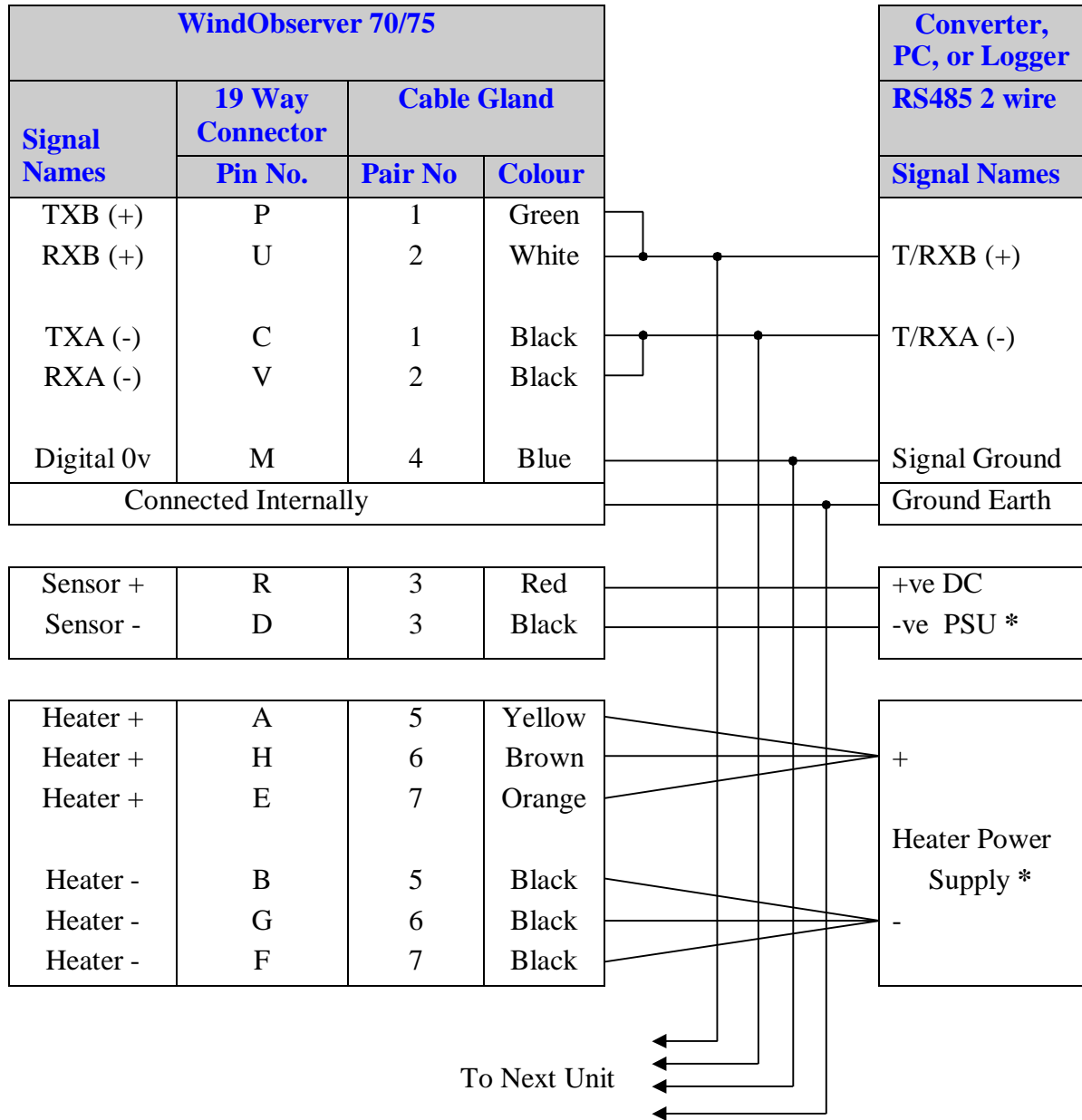

*For Power Supply Information see Section 6.4.

Notes:-

Heater Pair wires Yellow, Brown and Orange should be connected in Parallel, as too should the return 3 Black wires.

6.6. Indoor Power and Communications Interface (Part 1189-PK-021)

The desktop PCI is intended for use in a protected environment and provides interfacing and power to a single anemometer (Note a separate supply is required for heating).

The PCI is not intended for outdoor use.

Note a mains connector lead only is supplied with the PCI Box.

Connecting to a PCI Unit with RS422 input

WindObserver 70/75				PCI Box	
Signal Names	19 Way Connector	Cable Gland		15 Way D Type Connector	
	Pin No.	Pair No	Colour	Pin No.	Signal Name
TXB (+)	P	1	Green	2	RXB (+)
TXA (-)	C	1	Black	9	RXA (-)
RXB (+)	U	2	White	3	TXB (+)
RXA (-)	V	2	Black	10	TXA (-)
Digital 0v	M	4	Blue	4	Signal Ground
Sensor +	R	3	Red	5	Power V+
Sensor -	D	3	Black	11	Power 0v

To Connect the PCI RS232 Output (9 Pin D Type connector) to a PC RS232 9 way port to communicate with the sensor connect as follows:-

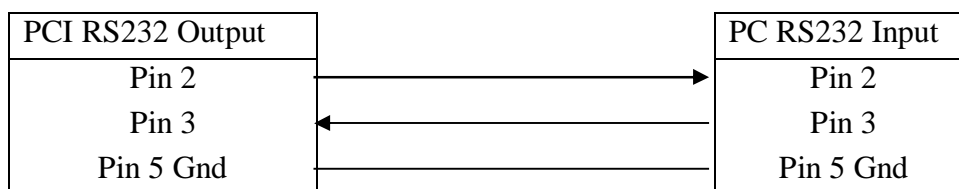

Environmental

PCI Electrical Power Requirements

- 1) 100Vac – 120Vac, 10VA for the 115V switch position
- 2) 200 Vac – 250Vac, 10VA for the 230V switch position
- 3) 20-30Vdc, 120mA max (anemometer)
8-15Vdc, 50mA max (interface)

3 Fuses protect the unit:

1. Externally accessible 315mA(T) for 115/230v operation
2. Internally accessible 500mA (T) AUX
3. Internally accessible 500mA (T) ANEM

PCI Connector Pin and Cable assignments

Anemometer connector – 15 way skt

Pin	Designation	(Example Plug MH Connectors MHDM15-DM15P-K)
1	Chassis	(e.g. RS Components 765-9494)
2	RS422_RXB (+)	
3	RS422_TXB (+)	
4	Digital 0V, Signal ground	
5	Supply V+	
6	Not Used	
7	Not used	
8	Not Used	
9	RS422_RXA (-)	
10	RS422_TXA (-)	
11	Supply V-	
12	Not Used	
13	Not Used	
14	Not used	
15	Not Used	

Auxiliary Analogue Outputs – 9 way (Not Applicable)

DC Supply – 4 way

Pin	Designation	Example Connector Amphenol CO91A
1	Interface V+	(e.g. T3301001)
2	Interface V-	
3	Anemometer V-	
4	Anemometer V+	

RS 232 Output – 9 way Skt

Pin	Designation	(Example Plug MH Connectors MHDM9-DM9P-K)
1	DCD	(e.g. RS Components 765-9485)
2	RX data	
3	TX data	
4	DTR	
5	Signal Ground	
6	DSR	
7	RTS	
8	CTS	
9	RI	

RS422 Network In – 9 way Skt

Pin	Designation	(Example Plug MH Connectors MHD9-DM9P-K)
1	Not connected	(e.g. RS Components 765-9485)
2	Not connected	
3	Not connected	
4	RS422_RXA (-)	
5	Signal ground	
6	RS422_TXA (-)	
7	RS422_TXB (+)	
8	RS422_RXB (+)	
9	Chassis	

RS422 Network Out – 9 way Plg

Pin	Designation	(Example MH Connectors MHD9-DM9S-K)
1	Not connected	(e.g. RS Components 765-9488)
2	Not connected	
3	Not connected	
4	RS422_RXA (-)	
5	Signal ground	
6	RS422_TXA (-)	
7	RS422_TXB (+)	
8	RS422_RXB (+)	
9	Chassis	

PCI Operation.

There are three Red LED's on the PCI front panel.

When the PCI box is powered the Power LED will illuminate.

When a WindObserver is connected as above to the PCI box and is set to output continuous data the PCI box RX LED will flash on/off at the WindObserver output rate thus giving a good indication that the WindObserver output is wired to the PCI box correctly and outputting RS422 data correctly.

If the PCI RS 232 connection is connected to a computer then when a terminal programme is opened and commands sent by a PC keypad or program to the PCI box its TX LED will illuminate intermittently indicating a good connection between the PC and PCI box.

6.7. Using the WindObserver 70/75 with the Gill WindDisplay

Marine WindDisplay

The WindObserver 70/75 is designed to interface with a Marine WindDisplay unit to provide a complete wind speed and direction system.

When coupled to a Gill supplied Marine WindDisplay (Fig 3), the WindObserver 70/75 must be set for NMEA (M5 setting, not default) and 4800 baud (B2 setting, not default).

In some installations NMEA, 9600 baud (B3 setting) is used and this would require re-configuring both the WindObserver and the display for 9600 baud to work.

If the WindObserver 70/75 is used in default CSV mode (O1) and a fault occurs then note that the WindDisplay may lock into the last valid reading. If required re-configuring the WindObserver 70/75 to Fixed Field output (O2) will ensure that any fault is flagged on the WindDisplay.

WindObserver 70/75, 4800 Baud and NMEA unheated configuration settings would be:-

A0 B2 C1 E1 F1 G0000 J1 K1 L1 M5 NA O1 P1 T1 U1 V1 X1 Y1 Z1

WindObserver 70/75, 4800 Baud and NMEA heated configuration settings would be:-

A0 B2 C1 E1 F1 G0000 H2 J1 K1 L1 M5 NA O1 P1 T1 U1 V1 X1 Y1 Z1

NOTE: Although the WindDisplay can show wind speed in various units, these are calculated within the WindDisplay. **The WindObserver data sent to the WindDisplay must be in metres/sec** (U1 factory default output setting).

Gill Supplied Marine Wind Display Part Numbers are:-

Gill Display Part	Supply Voltage	Data Format	Baud Rate
1086-PK-083	220V AC	NMEA	4800
1086-PK-084	110V AC	NMEA	4800

After coupling the WindObserver to a WindDisplay, the Wind Speed units and the Averaging period can be selected using the WindDisplay controls. *See the WindDisplay User Manual 1086-PS-0050 on the CD 1000-10-034.*

Figure 3 Gill Supplied Marine WindDisplay



Connections to a Gill Marine WindDisplay

If required the WindDisplay can provide a 15V DC supply voltage for the WindObserver sensor circuitry but cannot be used to provide a supply voltage for heater circuitry.

Refer to the WindDisplay User Manual 1086-PS-0050 on the CD 1000-10-034 for the method of operation.

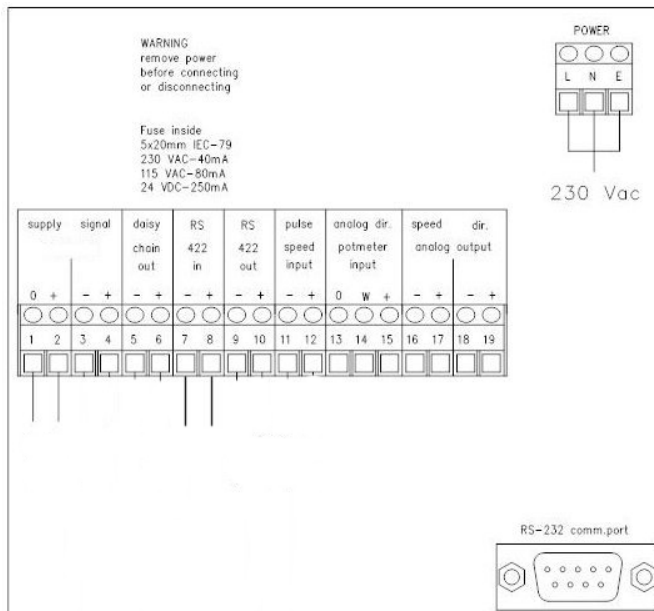

Wiring Connections

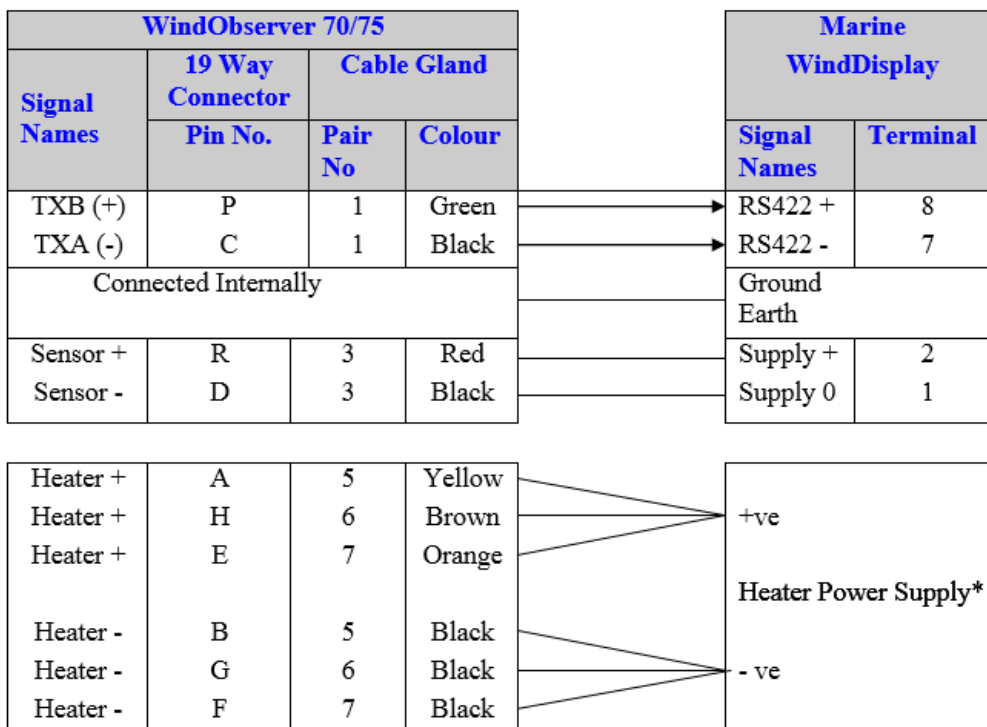

Notes:-

*For Heater Power Supply Information see Section 6.4.

Heater Pair wires Yellow, Brown and Orange should be connected in Parallel as to should the return 3 Black wires.

Heating (H2 command) is enabled as a default condition. If heating is not required enabled then the H command must be set for H1.

See Section 8, Configuring for further details.

Meteorological WindDisplay

The WindObserver 70/75 is designed to interface with a Meteorological WindDisplay unit to provide a complete wind speed and direction system.

To interface to the Meteorological WindDisplay the WindObserver must be set for NMEA (M5) and 4800 Baud (B2) configuration settings.

WindObserver 70/75, 4800 Baud and NMEA unheated configuration settings would be:-

A0 B2 C1 E1 F1 G0000 J1 K1 L1 M5 NA O1 P1 T1 U1 V1 X1 Y1 Z1

WindObserver 70/75, 4800 Baud and NMEA heated configuration settings would be:-

A0 B2 C1 E1 F1 G0000 H2 J1 K1 L1 M5 NA O1 P1 T1 U1 V1 X1 Y1 Z1

Meteorological Wind Display Part numbers are:-

Gill Part	Supply Voltage	Data Format	Baud Rate
1086-PK-120	100V to 240V AC	NMEA	4800
1086-PK-121	18V to 32V DC	NMEA	4800

NOTE: Although the WindDisplay can display wind speed in various units, these are calculated within the WindDisplay. **The WindObserver data coming to the WindDisplay must be in metres/sec (U1 factory default output setting).**



Meteorological WindDisplay

Connections to a Meteorological WindDisplay.

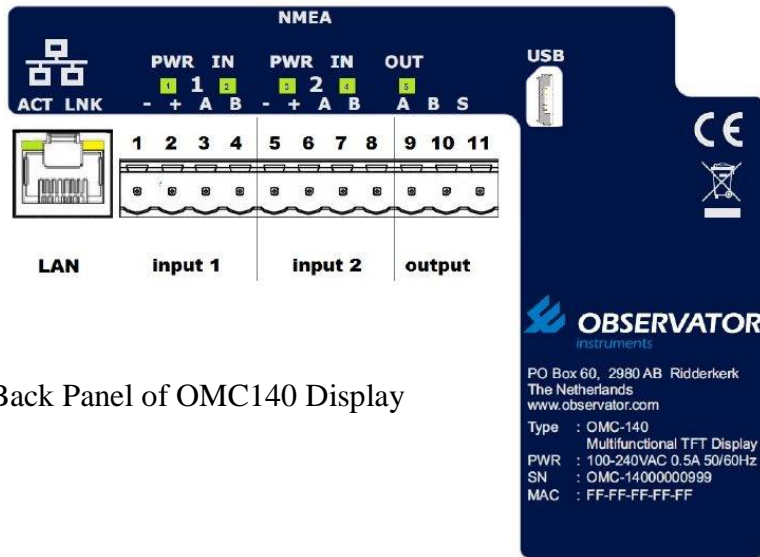

Back Panel of OMC140 Display

Wiring Connections

19 Way Connector Terminal Letter	Cable Gland Options		Signal Designation	Wind Display	
	Conductor	Colour		Pin Number	Designation
P	Pair 1	Green	RS422 TXB (+)	4	NMEA Input B
C		Black	RS422 TXA (-)	3	NMEA Input A
U	Pair 2	White	RS422 RXB (+)		N/C
V		Black	RS422 RXB (-)		N/C
R	Pair 3	Red	Supply +	2	Power out +15vdc
D		Black	Supply -	1	Power out Gnd
M	Pair 4	Blue	Digital 0v		N/C

Notes:-

Display supporting documentation is supplied on the CD 1000-10-034

- OMC-140 Operator Guide Wind.pdf
- OMC-140_Installation_Manual_v1.04_.pdf
- OMC-140_Operator_Manual_v1.04_.pdf
- 1086-PS-0055 Display to WindObserver Connection Guide.

6.8. Mechanical installation

Do NOT remove the black “rubber” transducer caps. Warranty is void if the Green security seal is damaged or removed.

Take care not to knock the four Transducer arms.

Before installing, a bench system test is recommended.

All the time the WindObserver 70/75 is not in its final location, it should be protected from damage by keeping it in the original packaging as long as possible, treating it as a delicate instrument.

When installing the unit handle with lint free gloves and degrease the unit to reduce the build-up of deposits.

Do not apply clamps to the WindObserver cylinder body as this will distort the cylinder and affect sealing.

Location

It is important to ensure that the WindObserver 70/75 is mounted in a position clear of any structure, which may obstruct the airflow or induce turbulence.

Do NOT mount the WindObserver 70/75 in close proximity of high-powered radar or radio transmitters. A site survey may be required if there is any doubt about the strength of external electrical noise. (See Section 6.1)

Orientation

Normally the WindObserver 70/75 is mounted vertically with the cable exit at the bottom.

Alternatively, the unit may be mounted in any orientation, but note that if the unit is mounted with the cable uppermost, the base **must** be fully sealed externally to prevent water penetration. Fit the supplied gasket if the 2 metal mounting faces are of dissimilar metals to prevent galvanic corrosion.

Mounting (Short and Long Mounts)

A suggested mounting bracket using Short or Long base mounts is shown in Fig 1.

It is recommended that the WindObserver 70/75 mounting bracket be manufactured from stainless steel 316, to prevent possible galvanic corrosion.

It is also recommended that the supplied gasket be always fitted to ensure IP66 rating and to prevent galvanic corrosion if the mounting bracket is not manufactured from stainless steel 316.

Stainless steel 316 fixings must be used.

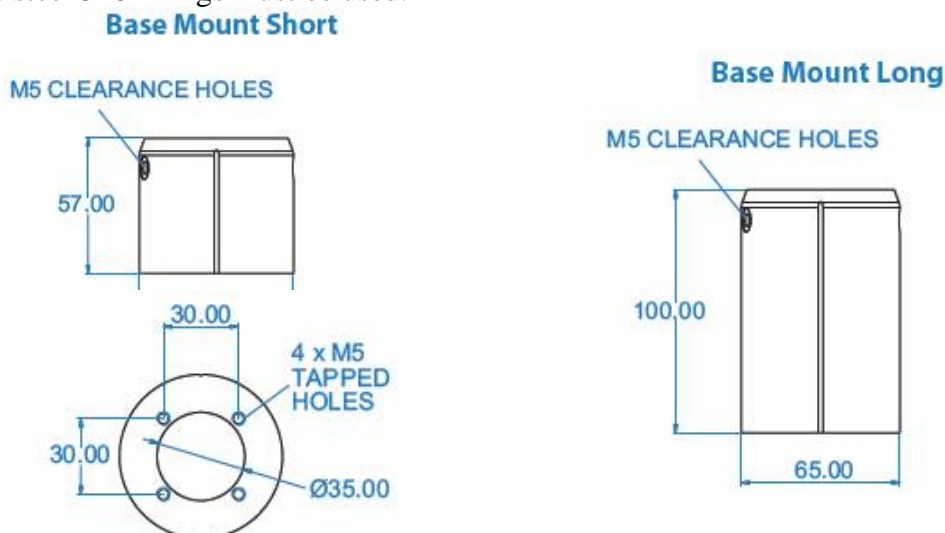

Figure 1. Suggested Mounting Bracket and Earthing (Grounding) Arrangement.

The example shows a long mount fitted to a cable gland unit, a similar Earthing/ mounting arrangement can be used with short mounts and connector based units.

A mounting kit (1390-10-164) is supplied with the WindObserver 70/75 to allow assembly of the mount to the base of the WindObserver.

Included in the supplied mounting kit is an O Ring Seal which must be fitted inside of the Base Mount.

Now fit the Base Mount to the WindObserver base using supplied 3 off M5x12 screws, first fit a wavy washer to them, then a flat washer, then the seal washer before screwing to the WindObserver Base mount.

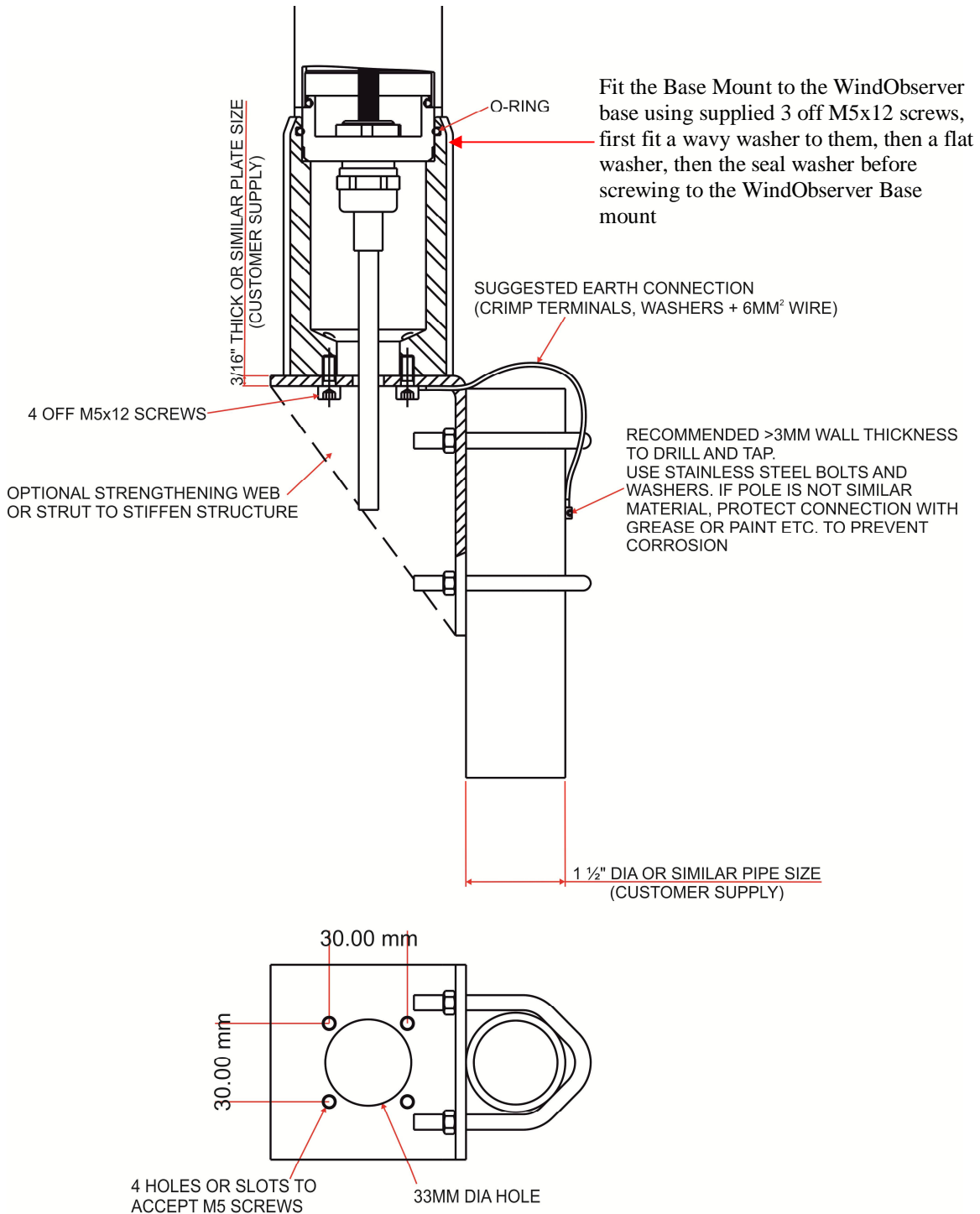

Pipe Mounting (use with Pipe Mount)

The Pipe Mount base for the WindObserver 70/75 has the following dimensions.

Included in the supplied mounting kit is an O Ring Seal which must be fitted inside of the Pipe Mount Base.

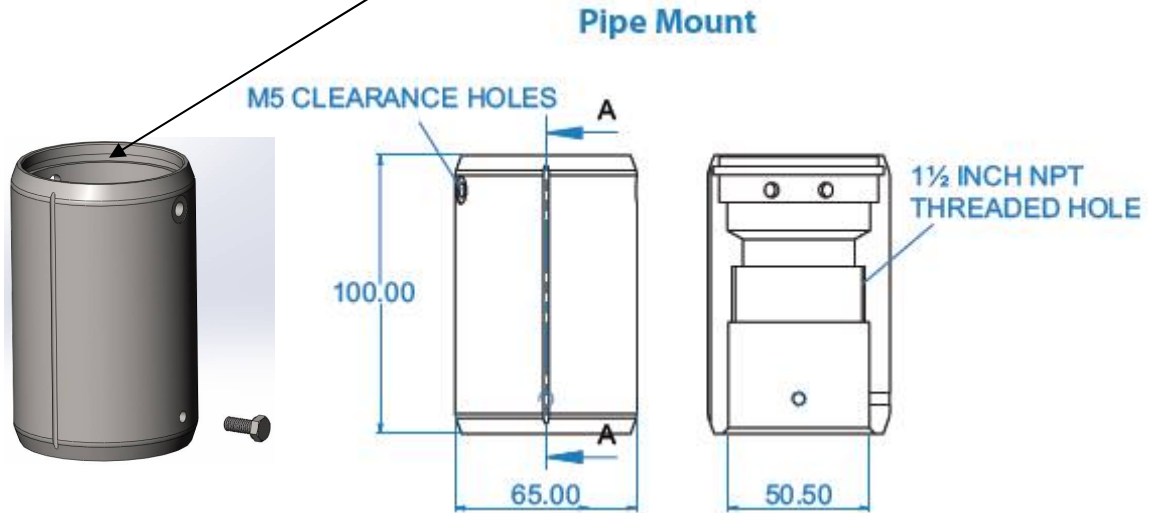

The mounting pole dimension should be 50mm (1.97") diameter.

Three M5 x 12 hex screws are provided to secure the Pipe Mount to the WindObserver base.

Three M5 x 12 hex screws to secure the Pipe Mount to the pipe through M5 tapped holes in the pipe mount.

If a screw threaded pole is used it should be a 1.5 inch National Pipe Thread (NPT) type. It is recommended that the WindObserver mounting pole be manufactured from Stainless Steel 316, to prevent possible galvanic corrosion.

Custom Mount (Use with WindObserver No Mount Option)

Although it is recommended that customers select a base mount option from Gill Instruments, should a customer wish to design their own mount then the WindObserver base dimension details for this are as follows:-

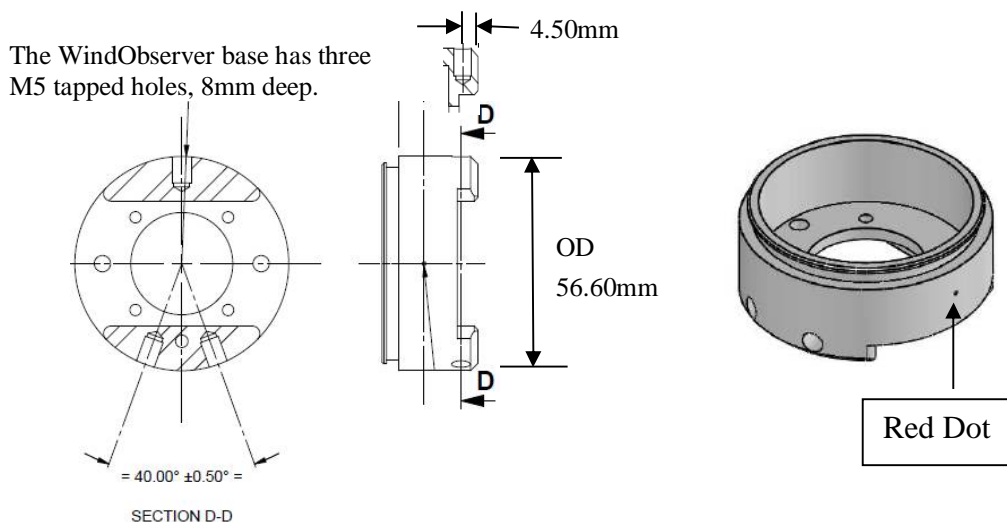

Alignment

The anemometer should be set to point North (or to another known reference direction), using the North Spar, which can be identified from the red dot on the base of the instrument or vertical groove on short base, long base or pipe mount adaptor.

See Figure 2a.

Since all wind measurements are made relative to the North Spar, it is important to use only the North Spar for alignment and not the red dot located at the base of the unit (only visible without base mount) nor vertical groove located on the base mount (only when fitted).

If the unit is used in a tunnel, (and the Tunnel format is used), the unit would normally be aligned with the N – S axis in the horizontal plane.

Figure 2a North Marker (Long Base Mount shown for illustrative purposes).

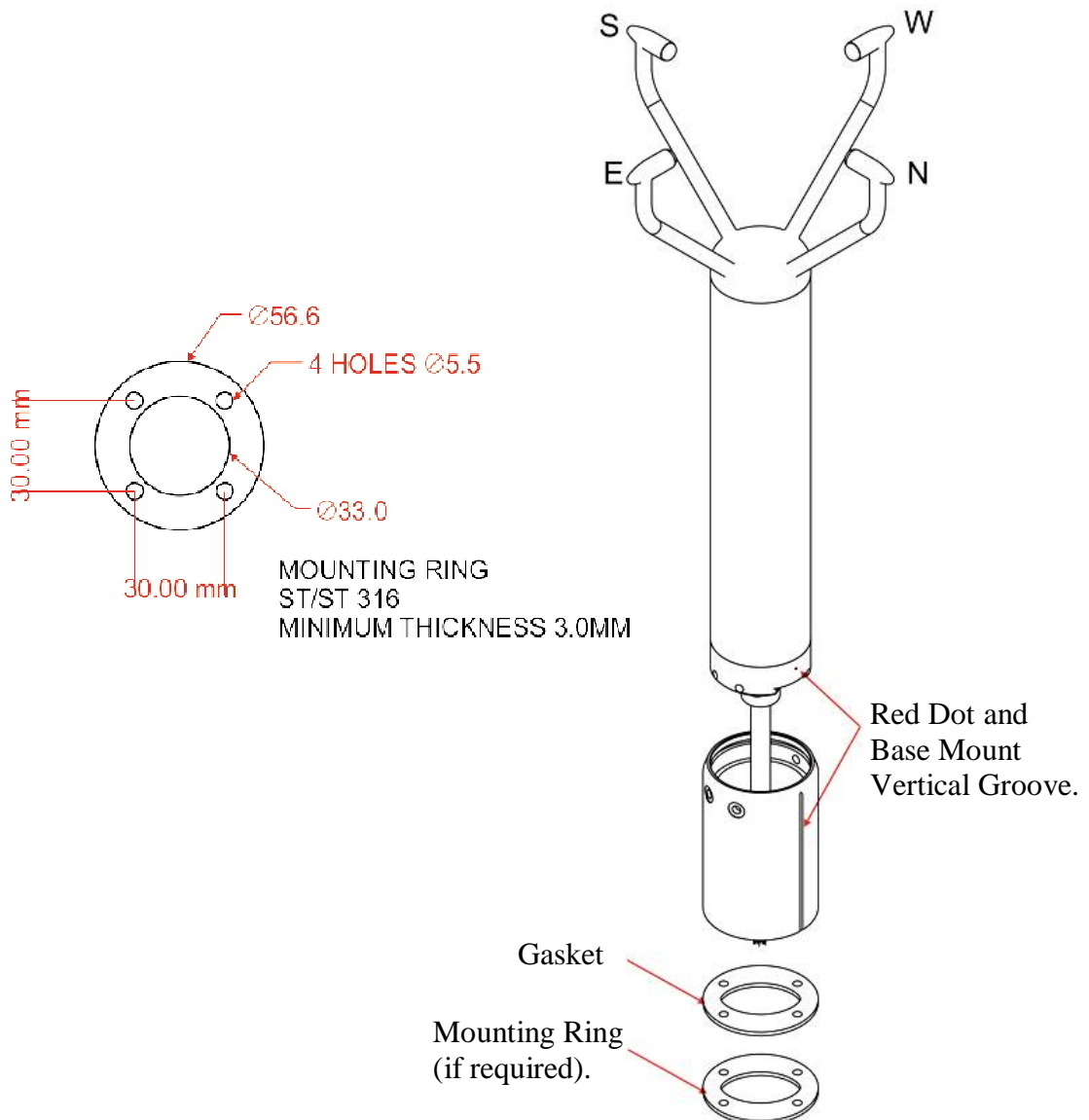

Pipe Mount units do not require the gasket and mounting ring.

Figures 2b WindObserver 70/75 Outline Dimensions with Mounts

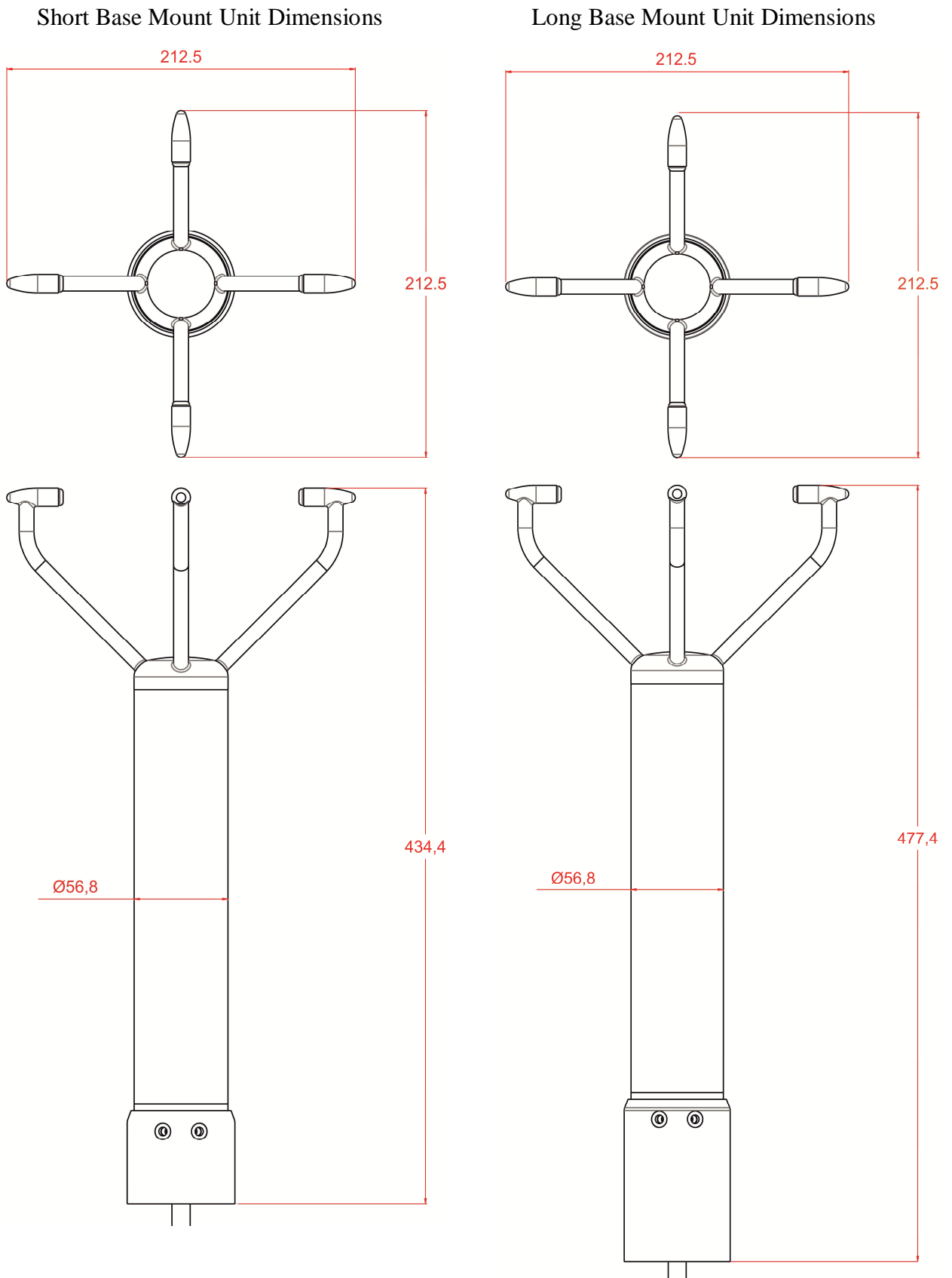

Pipe Mount Unit Dimensions

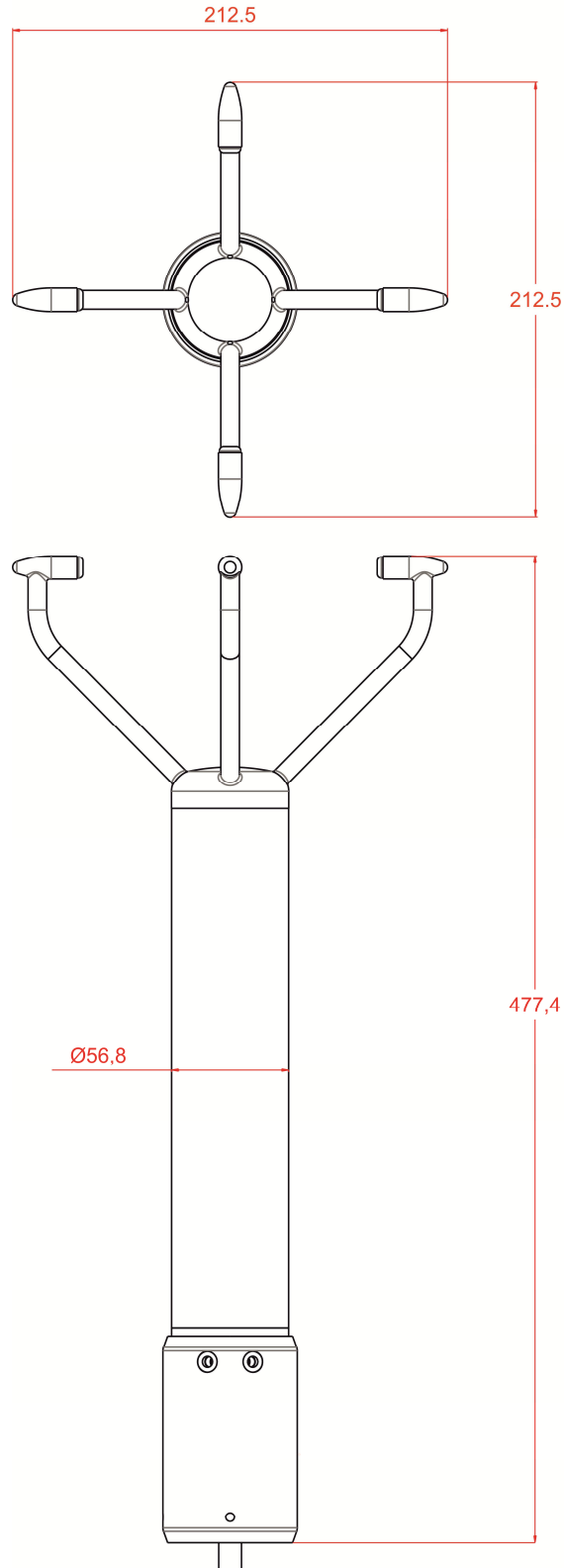

7. MESSAGE FORMATS & OPTIONS

On first applying power to the WindObserver 70/75, it will be in 'Measurement Mode', and it will output wind measurement information in one of the formats as described below.

Setting the output format, units, other parameters, options and the communication settings are all carried out in the alternative 'Configuration Mode'.

See Section8 CONFIGURING for details of how this is done.

*The factory default settings are shown here in **bold**, and for convenience some 'Configuration codes' (as used to set the configuration) are shown in blue boxes.*

For example M3.

7.1. Wind Speed format

The wind speed measurements can be output in one of the following formats: UV, Polar or NMEA.

7.2. Output formats

The UV and Polar wind speed parameters are output in ASCII.

These parameters can be transmitted continuously or polled from the user.

Polar is also available in continuous NMEA format.

Output Formats Table

Output format	Output see Notes below	Configuration code
ASCII UV	Continuous	M1
	Polled	M3
ASCII Polar	Continuous	M2
	Polled	M4
NMEA	Continuous	M5
ASCII Polar	Continuous Averaged	M15
ASCII Polar	Polled Averaged	M14

Notes:-

1. Continuous Output: In this mode the unit continuously outputs a burst of RS422 level data (the frequency determined by the output rate setting). After the burst of data and until the next data burst the data lines revert to a high impedance state.
2. Polled Output: In this mode the data lines are in a high impedance state until the unit is polled for data. Upon receipt of a poll command the unit outputs a burst of data at RS485 levels and then reverts to a high impedance state until the next poll command receipt.

Low wind speeds

Whilst the wind speed is below 0.05 metres/sec, the wind direction will not be calculated, and the last known good direction figure is shown. All other output parameters will continue to update at the output rate.

7.3. Networking

Gill Proprietary Network

Each anemometer connected to the network **MUST** be given a unique Unit Identifier (Letters A to Z), and set to a polled tri-state mode (UV or Polar) (M3 or M4).

In these modes the communications transmit line is tri-state unless the anemometer is responding to a command. If used in a multi drop system then it is recommended that Unit Identifiers A, B, C, D, E, F, K, M, N and P are not used.

Configuring WindObserver 70/75 for Half Duplex Operation.

- 1) Set up Two Terminals: One for RS485 Half Duplex and the other for RS422 Full Duplex.

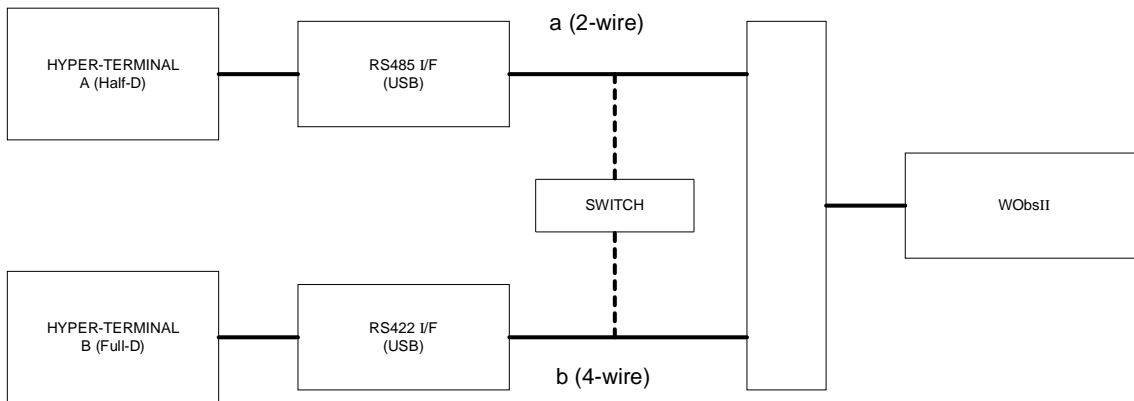

One PC (with two USB ports) can be used for both Terminals, although two may be less confusing.

Note: Power must not be disconnected from the anemometer throughout this procedure.

- 2) Assuming the unit is set for Full Duplex, connect 9-way at [b] disconnect 9-way at [a]. Set Switch to position [b] (4 wire).
- 3) On Terminal B, enter CONFIGURATION MODE. Set Half Duplex (E2). The CONFIRM> prompt will appear.
- 4) Disconnect 9-way [b] and connect 9-way [a]. Set Switch to position [a] (2 wire).
- 5) On Terminal A, type "E" <ENTER> to confirm.
- 6) The unit should now be configured in Half Duplex mode.

Configuring WindObserver 70/75 for Full Duplex Operation.

- 1) Assuming the unit is set for Half Duplex, disconnect 9-way [b] and connect 9-way [a]. Set Switch to position [a] (2 wire).
- 2) On Terminal A, type "E1" to select Full Duplex. The CONFIRM> prompt will appear.
- 3) Disconnect 9-way [a] and connect 9-way [b]. Set Switch to position [b] (4 wire).
- 4) On Terminal B type "E" <ENTER> to confirm.

7.4. Units

The wind speed can be set to any of the following units:

Unit	Abbreviation
Metres per sec	m/s
Knots	knots
Miles per hour	MPH
Kilometres per hour	kph
Feet per minute	fpm

7.5. Output rate

The output frequency can be set between 1 and 4 per second. The wind speed is sampled every 25ms, each axis being sampled sequentially. The following Table lists the possible outputs per second and the corresponding number of averaged samples. A 25ms sample period is used to process and output the results.

Outputs per Second	Sample Average
1	39
2	19
4	9

7.6. Averaging (Digital Data)

There are two digital averaging options:-

7.6.1 G Command Averaging.

Using the G Command in association with modes other than M14, M15 and polled modes.

The Averaging Period can be set from zero to 3600 secs. (1 hour). The default setting is zero. When averaging is enabled, data is output at a rate determined by the averaging period. The data is an average of valid data collected during the averaging period.

If G is set to zero then averaging settings will be disabled.

For instance if the unit is set for G0025 then every 25 seconds there will be a single result output that provides the average of the wind direction and magnitude data over the last 25 seconds.

```
A,219,000.78,M,60,^ 0D
A,202,000.79,M,60,^ 06
A,207,001.22,M,60,^ 0C
A,220,000.48,M,60,^ 04
```

7.6.2 Modes 14 and 15 Road Weather Averaging (RWA).

The averaging is implemented with reference to the following standard:

- Guide to Meteorological Instruments and Methods of Observation – World Meteorological Organization WMO-No8 seventh edition 2008 ISBN 978-92-63-10008-S

The direction and magnitude outputs are derived from the vector sum of U and V over the RWALONG averaging period (default 10 minutes in P1).

The gust output is derived from the vector sum of U and V over 3 readings (3 seconds in P1), and the max gust is the maximum of the gust value over the RWASHORT period (default 60 seconds in P1). The max gust value is reset to zero at the end of each RWASHORT period.

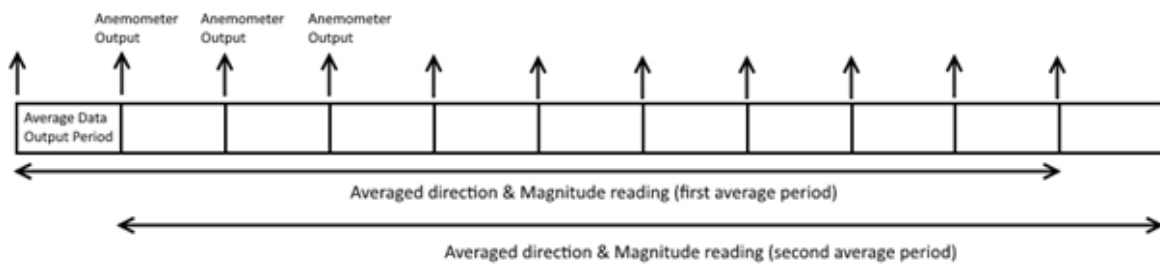

RWA Default settings are:-

P (Output rate Hz) = 1
RWASHORT = 60
RWALONG = 10

Therefore:

Anemometer output period = $60/1 = 60$ seconds (the WindObserver will output a reading every 60 seconds).

Averaged direction and magnitude reading = $10 \times 60 = 600$ seconds (this is the time the readings will be averaged over).

When the average building period has been completed, the average reported thereafter will be a rolling average derived from the last averaged direction and magnitude time period.

Mode 15 – Averaging Data in Continuous mode.

Averaged Digital Data Output comprises of.

<Start of String>, Unit Identifier, Mode, Averaged Direction, Averaged Magnitude, units, Maximum Gust Direction, Maximum Gust Magnitude, Status, <End of String>, checksum.

e.g.

0A,M15,293,000.03,M,338,000.05,51,♥47

(status code 51 shows measurement average building, non-heat enabled units only).

0A,M15,198,000.04,M,088,000.39,00,♥4B

(status code 00 code shows measurement average building period complete and normal operation, non-heat enabled units only).

Principle set up commands associated with this averaging mode are:-

Px:- Measurement Rate, (P1) this command sets the underlying measurement rate 1Hz.

RWASHORT xx: - Short Term Number, where xx is a number from 10 to 60.

RWALONG xx: - Long Term Number, where xx is a number from 1 to 10.

The Averaged Data Output period in seconds is:-

$$\frac{\text{RWASHORT Number}}{\text{Measurement Rate (P Setting Hz value)}}$$

Therefore with the RWASHORT number set for 60 (default) and P command set for 1Hz (P1 default) the unit will output a rolling averaged reading every 60 seconds.

The Averaged Direction and Magnitude reading is based on:-

$$\text{RWALONG Number} * \text{Averaged Data Output period.}$$

Therefore if the RWALONG number is 10 (default) and Averaged Data Output Period is 60 seconds, then the rolling averaged Direction and Magnitude data is calculated over rolling 600 readings.

```

0A,M15,293,000.03,M,338,000.05,51,47
0A,M15,301,000.03,M,304,000.04,51,43
0A,M15,299,000.03,M,285,000.02,51,4D
0A,M15,303,000.02,M,336,000.02,51,47
0A,M15,291,000.03,M,200,000.64,51,48
0A,M15,291,000.02,M,301,000.03,51,48
0A,M15,243,000.04,M,172,001.52,51,42
0A,M15,236,000.03,M,090,000.08,51,44
0A,M15,243,000.03,M,099,000.09,51,4E
0A,M15,198,000.04,M,088,000.39,00,4B
0A,M15,180,000.04,M,099,000.09,00,41
0A,M15,180,000.03,M,345,000.03,00,4E

```

The Maximum Gust Direction is the direction of the maximum gust measured over the short term output period. Gust is generated from a rolling 3s average of the short term output period, and reset at the end of short term output period.

The maximum Gust Magnitude is the magnitude of the maximum gust measured over the short term output period. Gust is generated from a rolling 3s average of the short term output period, and reset at the end of short term output period.

Notes:-

Non Heat Enabled Units - Whenever the unit is powered up then until the unit has reached its minimum long term averaging interval the status code will read 51 (Measurement Average Building).

Heat Enabled Units - On units where heat is enabled Code 51 will not be output during the measurement average building period, therefore allow for this period on power up before taking readings to be fully averaged (maximum period of 10 minutes).

The G Command setting has no effect on Mode 14 and Mode 15 Settings.

Mode 14 – Averaging Polled Mode

See Mode 15 for data output format and command explanations.

For ease of use before changing to this Mode set all other WindObserver parameters first including:-

Px:- Measurement Rate, (P1) this command sets the underlying measurement rate of 1Hz.

RWASHORT xx: - Short Term Number, where xx is a number from 10 to 60.

RWALONG xx: - Long Term Number, where xx is a number from 1 to 10.

Once set for Mode 14, to Poll for averaged data use the ? command followed by the unit designator A (default setting, ensure capitol letter used).

The polled mode commands available in this mode are:

Description	Command	WindObserver response
Enable Polled Mode	?	(None)
WindObserver Unit Identifier (N)	A.....Z	Output generated
Disable Polled mode	!	(None)
Request WindObserver Unit Identifier	&	A Z (as configured)
Enter Configuration mode	*<N>	CONFIGURATION MODE

Where <N> is the unit identifier, if used in a multi-drop system then it is recommended that ID's A to F and KMNP are not used as these characters can be present in the data string.

It is suggested that in polled mode the following sequence is used for every poll for information.

? Ensures that the Sensor is enabled to cover the event that a power down has occurred.

A-Z Appropriate unit designator (capitol letter) sent to retrieve a line of data.

! Sent to disable poll mode and reduce possibility of erroneous poll generation.

When polled with the default Mode 14 factory setting the WindObserver (set for default 1Hz output) will output the last valid 10 minute wind speed and direction average, updated every minute along with last valid 1 minute Gust magnitude.

Notes

Non Heat Enabled Units.

If the unit is powered up and polled before the unit has reached its minimum averaging interval the status code will read 51 (Measurement Average Building, non heat enabled units only).

Heat Enabled Units.

On units where heat is enabled Code 51 will not be output if polled during the measurement average building period, therefore allow for this period on power up before taking readings to be fully averaged (maximum period of 10 minutes).

```

0A,M15,293,000.03,M,338,000.05,51,47
0A,M15,301,000.03,M,304,000.04,51,43
0A,M15,299,000.03,M,285,000.02,51,40
0A,M15,303,000.02,M,336,000.02,51,47
0A,M15,291,000.03,M,200,000.64,51,48
0A,M15,291,000.02,M,301,000.03,51,48
0A,M15,243,000.04,M,172,001.52,51,42
0A,M15,236,000.03,M,090,000.08,51,44
0A,M15,243,000.03,M,099,000.09,51,4E
0A,M15,198,000.04,M,088,000.39,00,4B
0A,M15,180,000.04,M,099,000.09,00,41
0A,M15,180,000.03,M,345,000.03,00,4E

```

7.7. Heating Option

Heating is autonomous and requires no set-up once activated.

Upon unit switch on if heating is enabled and heater power available then a 1 minute burst of heating will occur to give confidence that the heating is functioning.

WARNING NOTE:-



When heating is activated the bullet and transducer arms will get very hot and should not be handled.

7.8. 45° Offset

If required, the U axis can be offset +45° to the transducer axis.

7.9. Vertical Output Padding

A dummy W vector is inserted to provide compatibility with any WindMaster that may be in a network.

7.10. ASCII message format (UV and Polar)

ASCII UV format

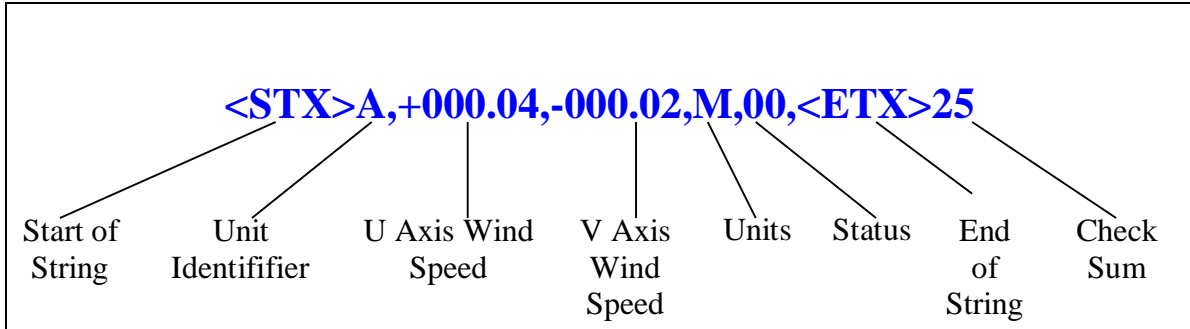

Where

U axis wind speed In increments of 0.01 units (\pm UUU.UU)

V axis wind speed In increments of 0.01 units (\pm VVV.VV)

Units	Value	Units
	M	Metres per second (m/s)
	N	Knots (knots)
	P	Miles per hour (MPH)
	K	Kilometres per hour (kph)
	F	Feet per minute (fpm)

Start of string ASCII value 2

Unit identifier Letter A – Z (default A)

Status	Value	Status
	0	OK
	60 or 66	Heating enabled and OK if enabled
	Any other value	Warning or fault condition - see Section 10.5

End of string ASCII value 3

Check sum Exclusive OR of all characters between Start of String and End of String reported as ASCII hex.

ASCII Polar format

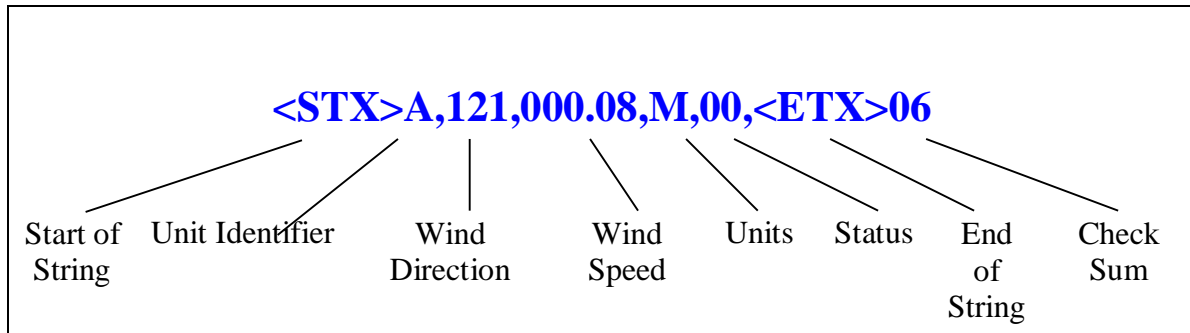

Where

Wind direction	In degrees relative to N (DDD)
Wind speed	In increments of 0.01 units (\pm MMM.MM)
All other parameters	See Section 7.10 ASCII UV format

ASCII Polled (UV and Polar)

When in the Polled mode, an output is only generated when the host system sends a Poll signal to the WindObserver consisting of the WindObserver Unit Identifier – that is, the relevant letter A – Z.

The output formats are otherwise as described above.

The commands available in this mode are:

Description	Command	WindObserver response
WindObserver Unit Identifier	A Z	Wind speed output generated
Enable Polled mode	?	(None)
Disable Polled mode	!	(None)
Request WindObserver Unit Identifier	&	A Z (as configured)
Enter Configuration mode	*<N>	CONFIGURATION MODE

Where <N> is the unit identifier, if used in a multi-drop system then it is recommended that ID's A to F and KMNP are not used as these characters can be present in the data string.

It is suggested that in polled mode the following sequence is used for every poll for information.

? Ensures that the Sensor is enabled to cover the event that a power down has occurred.

A-Z Appropriate unit designator sent to retrieve a line of data.

! Sent to disable poll mode and reduce possibility of erroneous poll generation.

When in polled mode the system will respond to the data command within 30mS with the last valid data sample as calculated by the Output rate (P Mode Setting).

If the unit is powered down after use or upon switch on then allow 3 seconds from switch on before sending poll commands.

7.11. NMEA Format

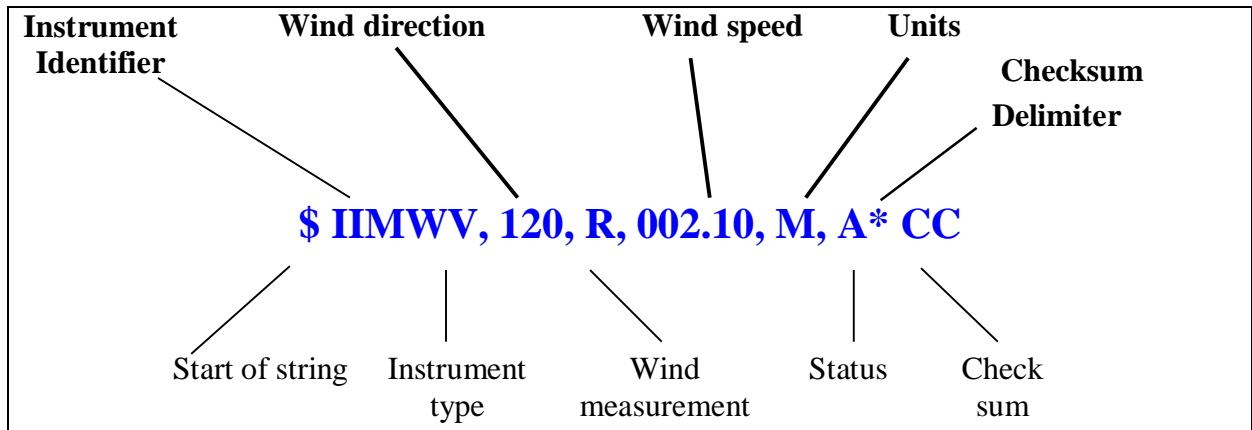

Where

Wind direction	In degrees relative to N (DDD)		
Wind speed	In increments of 0.01 units (\pm MMM.MM)		
Units	M	Metres per second (m/s)	
	N	Knots (knots)	
	P	Miles per hour (MPH)	
	K	Kilometres per hour (kph)	
	F	Feet per minute (fpm)	
Start of string	\$		
Instrument type	IIMWV		
Wind measurement	R	Relative wind measurement	
Status	A	Acceptable measurement	
	V	Void measurement	
Check sum	Exclusive OR of all characters between '\$' and '*' reported as ASCII hex.		

A typical WindObserver 70/75 configuration suitable for NMEA would be:

B2, E1, F1, G0, K1, L1, M5, O1, P1, U1.

Consult specification NMEA 0183 version 3 (available on the web) www.nmea.org for complete interface details.

7.12. Averaging Format (Modes 14 and 15)

See also Para 7.6.2.

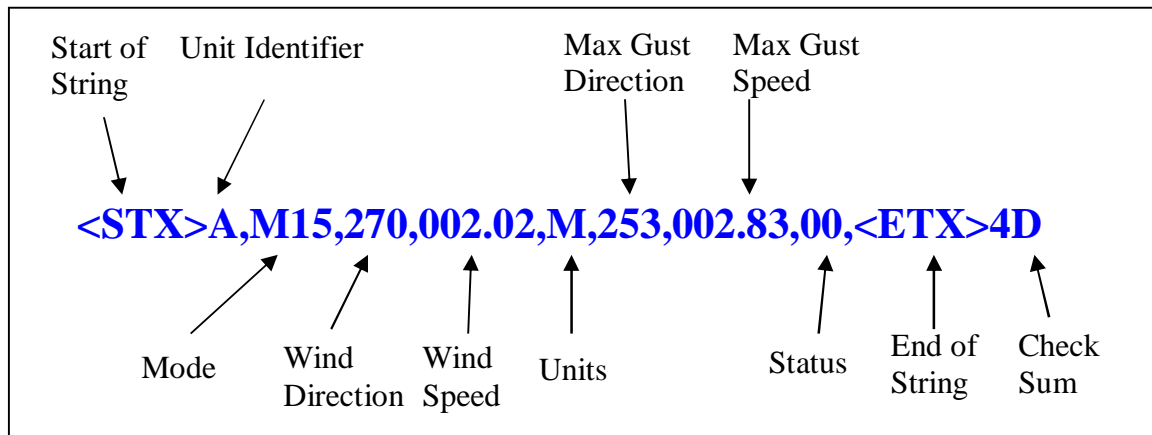

Start of string	ASCII value 2	
Unit identifier	Letter A – Z (default A)	
Mode	M14	Polled Averaging
	M15	Continuous Output Averaging
Wind Direction		In degrees relative to North (DDD) settable average of direction in degrees.
Wind Speed		In increments of 0.01 units (\pm MMM.MM), settable average of speed in m/s.
Units	M	Metres per Second
	N	Knots
	P	Miles per Hour
	K	Kilometres per Hour
	F	Feet per Minute
Max Direction Gust		In degrees relative to North (DDD)
Max Gust Speed		In increments of 0.01 units (\pm MMM.MM)
Status	Value	Status
	00	OK
	60	Heating enabled and OK if enabled
	51	Means that the averaging is incomplete (non-heat enabled units only).
	Any other value	Warning or fault condition - see Section 10.5
End of string	ASCII value 3	
Check sum	Exclusive OR of all characters between Start of String and End of String reported as ASCII hex.	

8. CONFIGURING

The WindObserver 70/75 can be configured using Terminal emulator software such as HyperTerminal.

Alternatively it is possible to use Gill Wind Software as a Terminal program only (Wizard and Sync Comms not applicable). Wind will run on PC's up to and including Windows 10 and can be downloaded from:-<http://www.gillinstruments.com/main/software.html>.

8.1. Configuring using HyperTerminal

Note – Other terminal emulators are configured in a very similar way.

1. Decide on an available Com port that you want to use (Usually Com1).
2. Run Hypertrm.exe.
3. Create a New Connection (File → New Connection)
4. Enter a **Name** (eg WindObserver) .
5. Change '**Connect Using**' to 'Direct to Com 1' (or other Com port as required)
6. Adjust the Port settings to match WindObserver settings. WindObserver default settings are :

Bits per second 9600

Data bits 8

Parity None

Stop bits 1

Flow Control (Handshaking) None

Click on OK and data similar to the following example will scroll on screen at the output rate:

☺ A, 229, 002.74, M, 00, ♥ 06

8.2. Entering Configuration mode

From Continuous mode

From Polled mode

- where N is the Unit Identifier.

Note - the Unit Identifier must be entered as upper-case

The WindObserver 70/75 responds with a CONFIGURATION MODE message, stops reporting wind measurements, and waits for a command (as detailed below).

8.3. Returning to Measurement mode

Type Q and press ENTER

If in **Continuous** mode, the anemometer responds with wind measurements immediately, continuing at the selected Sampling rate.

If in **Polled** mode,

- ?** Enables poll
- N** Polls anemometer (where N is the Unit identifier entered as upper-case)
The anemometer replies with a single set of wind measurements
- &** Anemometer replies with Unit identifier
- !** Disables poll

Note:- If the unit is in Polled Mode it is always best to interrogate the unit for data with a **?** before the poll identifier to cater for the event that the power has been switched off or power interrupted.

If used in a multi drop system then it is recommended that Unit Identifiers A, B, C, D, E, F, K, M, N and P are not used.

8.4. Checking the configuration

We strongly recommend that, as a standard procedure, you use this command (**D3**) prior to, and after, changing any settings. It shows the current settings for all the alterable settings. We suggest you note down your settings, so that you can easily return to them.

Type * Enters Configuration Mode (from Continuous mode)

Or **Type * N** Enters Configuration Mode (from Polled mode)

Type D3 and press ENTER The WindObserver 70/75 responds with the current settings.

The factory default settings for a heated unit are: -

A0 B3 C1 E1 F1 G0000 H2 J1 K1 L1 M2 NA O1 P1 T1 U1 V1 X1 Y1 Z1

Or factory default settings for an unheated Unit are:-

A0 B3 C1 E1 F1 G0000 J1 K1 L1 M2 NA O1 P1 T1 U1 V1 X1 Y1 Z1

To return to Measurement mode **Type Q and press ENTER**

How to change these settings is explained in the following sections.

8.5. Changing settings

To change a setting, first go into Configuration mode and then refer to the sections below. Enter the Configuration code of the new setting required, followed by **ENTER**. If successful, the new setting will be echoed back as a message by the WindObserver 70/75.

For example, to change the message format to NMEA, enter **Type M5 and press ENTER**. The WindObserver 70/75 will reply with **M5**. When the unit is returned to the Measurement mode **Type Q and press ENTER**, it will be in NMEA format.

Note: The factory-set (default) settings are shown in **bold** in the following sections.

8.6. Configuration Settings

Ax – Not Applicable

Bx - Baud Rate

Setting	Configuration code
2400	B1
4800	B2
9600	B3
19200	B4
38400	B5
1200	B6

To change the Baud rate when using HyperTerminal: -

Eg. If set to B3 (9600 baud) and it is required to set to Baud rate to B2 (4800 baud).

Type ***** to enter Configuration Mode.

Type **B 2** and press **ENTER**, (**Do not type any further commands at this stage**).

Close the 9600 Baud HyperTerminal connection.

Open HyperTerminal and set the new connection Baud Rate to 4800 baud.

Type **B** and press **ENTER**, the letter B will be shown followed by Capital B2

Type **Q** and press **ENTER**, data will scroll at the new baud rate.

Cx- Not applicable.

Dx- Diagnostic and Configuration Command (see also Section 10.6)

Each of these commands causes a response from the WindObserver 70/75.

Item	Command code	Typical response
Type and Serial No.	D1	*12400001 (where * = E (Unheated unit) or F (Heated Unit))
Software version	D2	6.01
Unit configuration	D3	Current configuration: A0 B3 C1 E1 F1 G0000 H2 J1 K1 L1 M2 NA O1 P1 T1 U1 V1 X1 Y1 Z1
Analogue ID (if present)	D4	No analogue fitted.
Anemometer power supply voltage	D5	+29.8
Integrity check	D6	See Para 10.6 Bench Tests

Ex - Full Duplex/Half Duplex Mode

Setting	Configuration code
Full duplex	E1
Half duplex	E2

Note: - Refer also to Para 7.3 Networking Configuration details.

Fx- Data and Parity Options

Setting	Configuration code
8 bits, no parity, 1 stop bit	F1
8 bits, even parity, 1 stop bit	F2
8 bits, odd parity, 1 stop bit	F3

Note: If changing to F2, using a Terminal program then when in configuration mode Type F2 and press Enter, close the terminal program and open a new one with Even parity settings, then type F and press Enter.

Gx to Gxxxx - Averaging (Digital Outputs only)

Setting	Configuration code
Averaging (Default)	G0000

Enter the required averaging period in seconds as a four-figure number between 0000 and 3600.

Hx - Heating

Heating is autonomous and requires no set-up once activated.

Setting	Configuration code
Disabled	H1
Activated	H2
Activated	H3

H2 command selects heater fault codes 62, 63, 64 and 65.

H3 command selects heater fault codes 66, 67, 68 and 69.

Jx - Not applicable

Kx – NMEA Settings

Setting	Configuration code
NMEA string “IIMWV”	K1
NMEA string “WIMWV”	K2

Lx - ASCII Message Terminator

Setting	Configuration code
CR LF	L1
LF	L2

Mx to Mxx - Message Format

Output format	Configuration code
ASCII UV Continuous	M1
ASCII Polar Continuous	M2
ASCII UV Polled (tri-state) *	M3
ASCII Polar Polled (tri-state) *	M4
NMEA Continuous	M5

* If units are to be networked, they MUST be given unique Unit Identifiers.

Nx – Unit Identifier Address

Item	Options	Command
Unit Identifier Address	A... -(A to Z)	N<A>

If used in a multi-drop system then it is recommended that ID's A to F and K, M, N and P are not used, as these characters can be present in the data string.

Ox – ASCII Output Format (Output String Padding)

Setting	Configuration code
Comma Separated Variable (CSV)	O1
Fixed Field	O2

Example data strings:-

POLAR	NMEA
CSV data changing to error status code condition.	CSV data changing to error status code condition.
⌈ A,235,000.77,M,60,⌋ 0A	\$IIMWV,191,R,000.55,M,A*19
⌈ A,,M,04,⌋ 24	\$IIMWV,,R,,M,V*29
Fixed Field data changing to error status code condition.	Fixed Field data changing to error status code condition.
⌈ A,266,000.73,M,60,⌋ 08	\$IIMWV,191,R,000.55,M,A*19
⌈ A,999,999.99,M,04,⌋ 0A	\$IIMWV,999,R,999.99,M,V*07

Px - Output Rate

Outputs per second	1	2	4
Configuration code	P1	P3	P2

Q- Measurement Mode

See Section 8.3.

RWASHORT XX (Short term number)

Where XX = 10 to 60, associated with Mode 14 and Mode 15 averaging.

RWALONG XX (Long term number)

Where XX = 1 to 10, associated with Mode 14 and Mode 15 averaging.

Tx - Not Applicable.**Ux – Digital Output Units**

Units	metres/sec (m/s)	knots (knots)	miles / hour (MPH)	kilometre/hour (kph)	feet / minute (fpm)
Configuration code	U1	U2	U3	U4	U5

Vx- Vertical Output Padding

Setting	Configuration code
Disable vertical output padding	V1
Enable vertical output padding	V2

Xx - 45° Alignment Offset/Inverted Operation

Setting	Configuration code	Notes
Align U axis with transducer axis	X1	X1. Aligns U axis with North/South axis.
Align U axis +45° to transducer axis	X2	X2. This re-aligns both U&V and polarity 45° to transducer axis.
Reverses Polar Direction	X3	X3 reverses reported polar direction to allow the instrument to be mounted upside down. N.B. Does NOT affect UV alignment (Mode 1, 3).
Align @ 45° from North	X4	X4 set polar alignment at 45 degrees from North when instrument is mounted upside down. Does NOT affect UV alignment (Mode 1, 3).

Figure 4 shows the polarity of U and V if the wind components along the U and V axis are blowing in the direction of the respective arrows.

Figure 4 UV Polarity

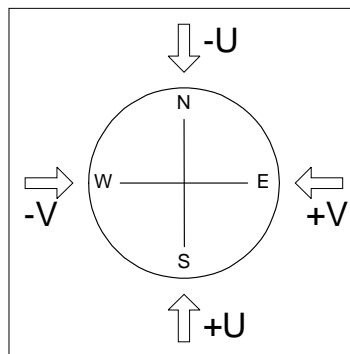
**Yx – Not Applicable.****Zx – Not Applicable.**

9. VIEW AND LOG DATA WITH WINDVIEW SOFTWARE

9.1. Introduction

Gill WindView Software is supplied on the CD with the WindObserver.

Alternatively it can be downloaded from <http://gillinstruments.com/main/software.html>

Gill Wind View will run on PC's with Windows XP onwards operating systems.

9.2. Connect to an Instrument using Gill WindView Software

Open WindView Software.

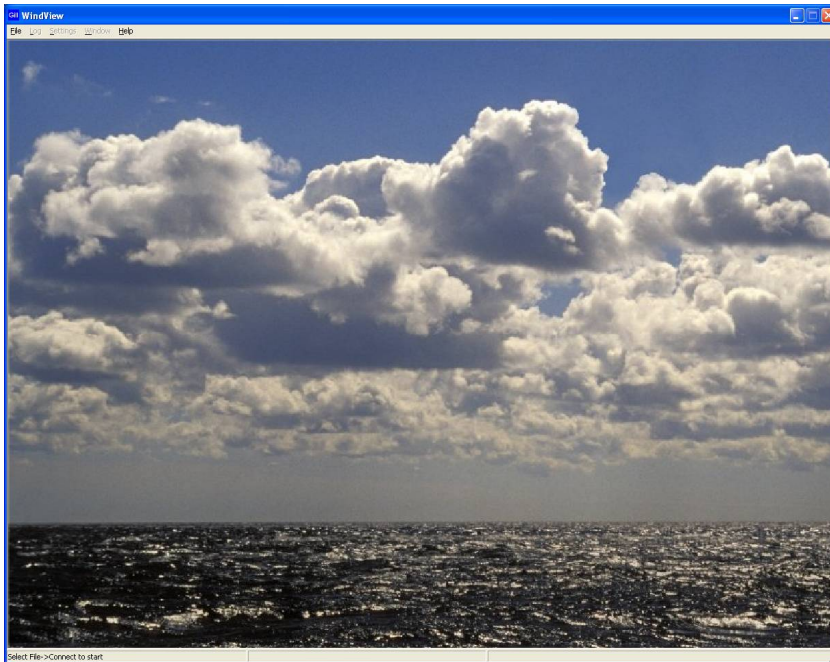

Select File/Connect.

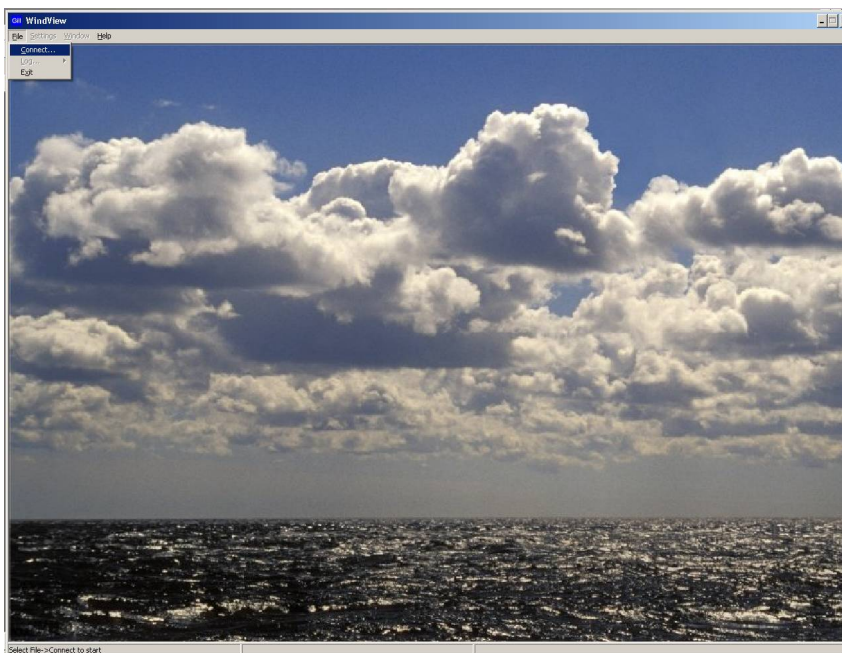

The default connection name is Anemometer 1, it can be re-named if required.

Select the Output Format to match the Sensor format i.e. the WindObserver default format is Gill Polar (2 axis).

If the WindObserver were set for UV or NMEA output then choose the appropriate format setting from the drop down menu.

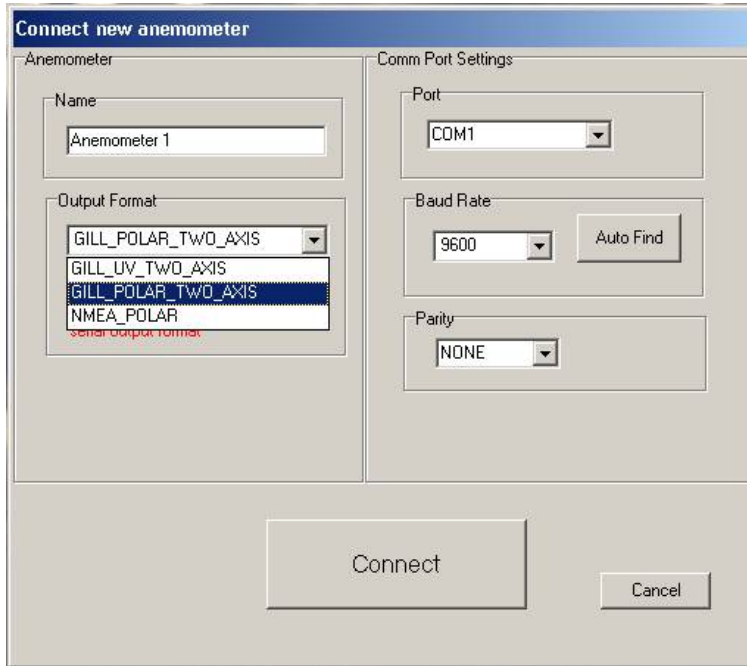

From the Port drop down menu select the PC COM Port to which the WindObserver is connected to e.g. COM 9.

Select the Baud rate setting from the drop down menu to match that of the Windobserver, the WindObserver default baud rate is 9600 baud.

Leave Parity setting at None.

Click on Connect.

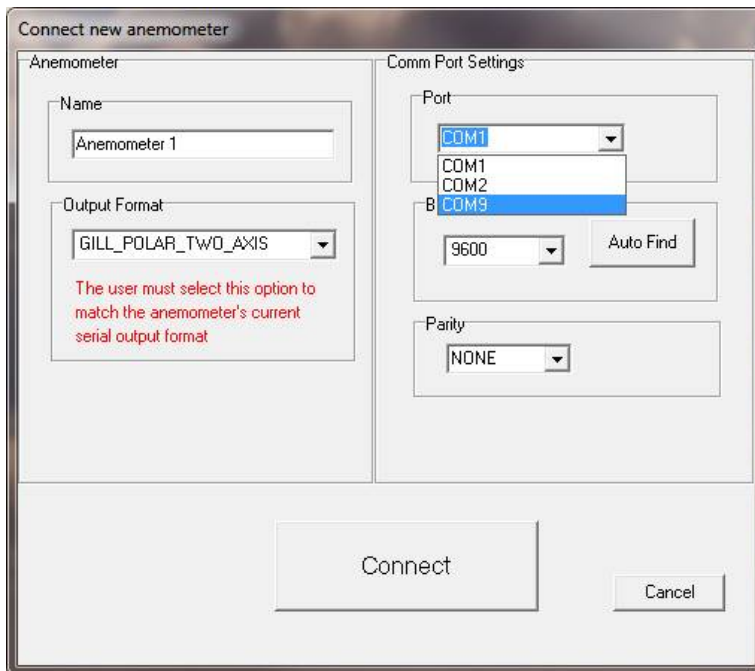

The Data button screen will show the WindObserver data scrolling on screen updated at the WindObserver Output rate.

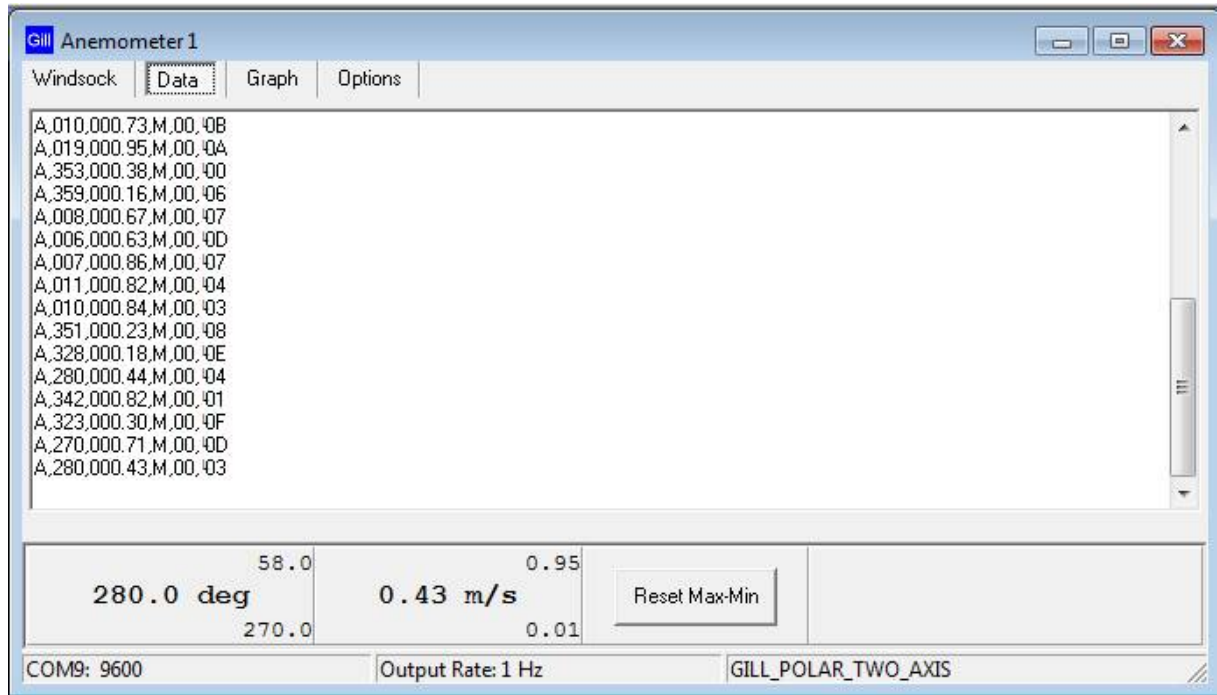

9.3. WindSock Function

Click on the WindSock button to give a Direction display and digital readout of Direction and Wind Speed:-

On screen Maximum and Minimum readings of Wind speed and Directions are also displayed digitally and can be reset using the Reset Max/Min button.

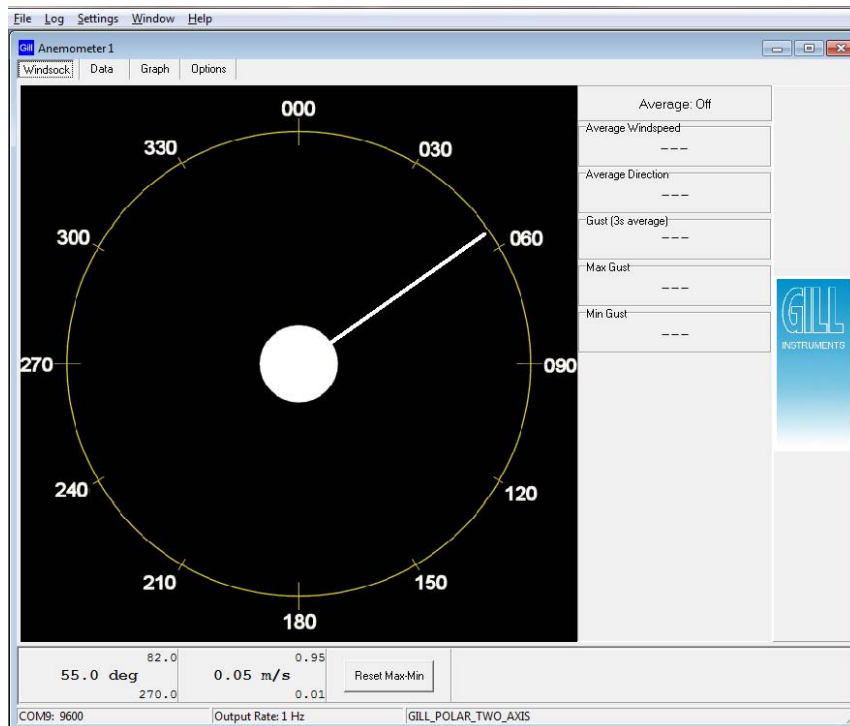

9.4. Logging Data.

To Log WindObserver data, from the WindView top menu select Settings/Logging. If Segmented log files are required tick the Enable box and select the length of each log file.

Tick the Record Formatting box options for Appending PC Time and Date Stamp and sequential line numbering as required.

Date and Time are taken from the PC clock.

The Log Description box allows a free text file header to be added to the log file.

Save the Log file to the required Directory.

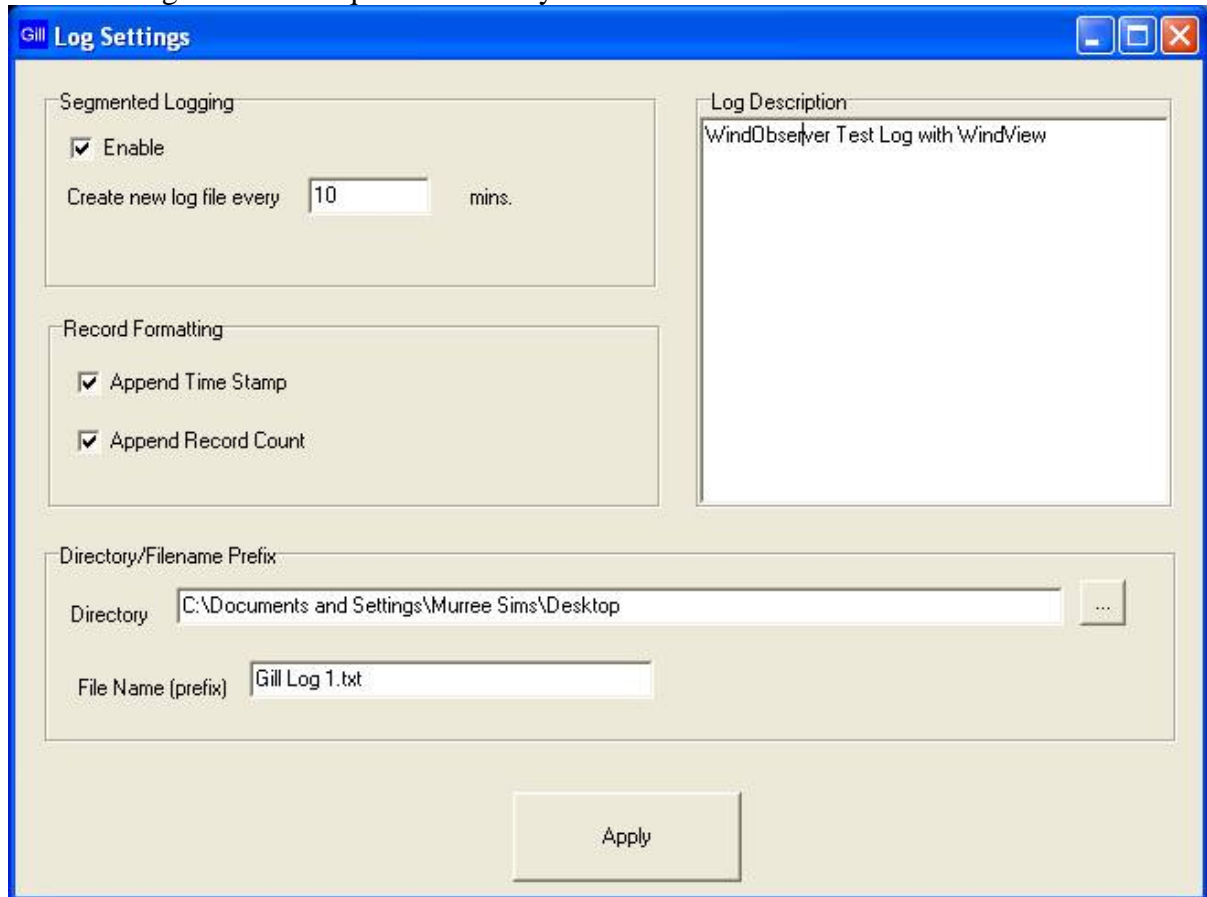

Click on Apply gives the following screen, click on OK:-

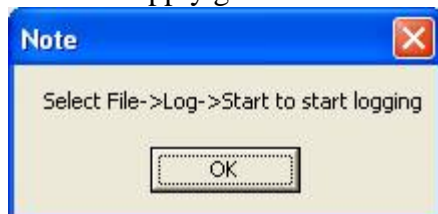

To Start Logging.

From the top menu select Log.

Click on Log/Start to commence logging.

To Stop Logging.

From the top menu select Log.

Click on Log/Stop to stop logging.

The logged data is saved to a PC text file that can be opened with Notepad or equivalent and the following example illustrates the saved time/date stamped WindObserver data.
Note: The Data and time information are taken from the PC Clock.

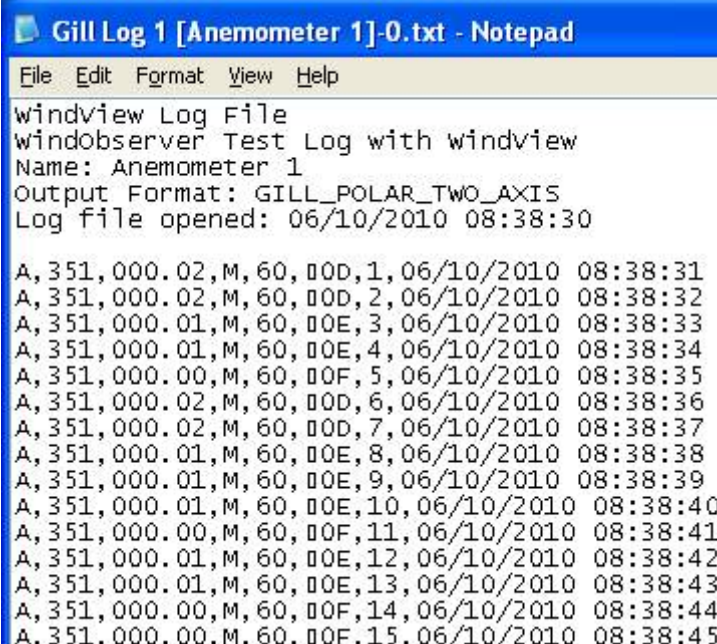

```
Gill Log 1 [Anemometer 1]-0.txt - Notepad
File Edit Format View Help
windview Log File
windObserver Test Log with windview
Name: Anemometer 1
Output Format: GILL_POLAR_TWO_AXIS
Log file opened: 06/10/2010 08:38:30

A,351,000.02,M,60,00D,1,06/10/2010 08:38:31
A,351,000.02,M,60,00D,2,06/10/2010 08:38:32
A,351,000.01,M,60,00E,3,06/10/2010 08:38:33
A,351,000.01,M,60,00E,4,06/10/2010 08:38:34
A,351,000.00,M,60,00F,5,06/10/2010 08:38:35
A,351,000.02,M,60,00D,6,06/10/2010 08:38:36
A,351,000.02,M,60,00D,7,06/10/2010 08:38:37
A,351,000.01,M,60,00E,8,06/10/2010 08:38:38
A,351,000.01,M,60,00E,9,06/10/2010 08:38:39
A,351,000.01,M,60,00E,10,06/10/2010 08:38:40
A,351,000.00,M,60,00F,11,06/10/2010 08:38:41
A,351,000.01,M,60,00E,12,06/10/2010 08:38:42
A,351,000.01,M,60,00E,13,06/10/2010 08:38:43
A,351,000.00,M,60,00F,14,06/10/2010 08:38:44
A,351,000.00,M,60,00F,15,06/10/2010 08:38:45
```

The logged Wind Data .txt file can be imported into Microsoft Excel if it is required to manipulate the data or graph plot the data.

10. MAINTENANCE & FAULT-FINDING

10.1. Cleaning and Handling

When installing the unit handle with lint free gloves and degrease the unit to reduce the build-up of deposits.

If there is any build-up of deposit on the unit, it should be gently cleaned with a cloth, moistened with soft detergent. Solvents should not be used, and care should be taken to avoid scratching any surfaces. The unit must be allowed to defrost naturally after being exposed to snow or icy conditions, do NOT attempt to remove ice or snow with a tool.

When heating is activated the bullet and transducer arms will get very hot and should not be handled.

Do NOT remove black “rubber” transducer caps.

10.2. Servicing

There are no moving parts or user-serviceable parts requiring routine maintenance.

Opening the unit or breaking the security seal will void the warranty and the calibration.

In the event of failure, prior to returning the unit to your authorised Gill distributor, it is recommended that:

- All cables and connectors are checked for continuity, bad contacts, corrosion etc.
- A bench test is carried out as described in Section 10.6.
- Contact your supplier for advice if failure persists.

10.3. Fault-finding

Symptom	Solution
No output	Check DC power to WindObserver 70/75, cable and connections. Check comms settings of WindObserver 70/75 (as detailed in Section 8) and host system match, including correct Com port Check unit is in Continuous mode Check that in-line communication devices are wired correctly. NOTE: It is usual for Anemometer TX + to be connected to converter device RX +
Corrupted output	Check comms settings of WindObserver 70/75 and host system match. Try a slower baud rate. Check cable lengths and type of cable.
One way communication	Check wiring is in accordance with the manual.
Failed/Incorrect output, data invalid flag	Check that transducer path is not blocked

10.4. Safe Mode

If a unit is received that will not communicate or the configuration settings are not known then Safe Mode can be used to establish communication with the WindObserver 70/75 and change configuration settings.

Initial Set Up.

The WindObserver 70/75 RS422 Pair 1 and Pair 2 TX and RX output connections (4 wires) are connected to a PC via an RS422 to RS232/USB Converter.

Open a Terminal program e.g. Windows HyperTerminal (or use Gill Wind Software as a Terminal program).

Select the required COM port.

Set the Baud rate to 19200 baud (if using the Wind Terminal program it opens at 19200 baud).

To Place the unit into Safe Mode.

Turn off the WindObserver 70/75.

Ensure the Terminal program is set for **19200** baud,

Hold down the PC keyboard * key and turn on the WindObserver 70/75 Power Supply.

The words SAFE MODE should appear on the terminal screen.

If not then power down the WindObserver 70/75, hold the * key and re-power sensor.

To now check the unit: -

Type D1 and press Enter, to see serial number.

Type D2 and Press Enter to see Firmware version.

Type D3 to see configuration settings,

```
SAFE MODE
D1
F922036
D1
D2
5.00
D2
D3
current configuration :
A0 B2 C1 E1 F1 60000 H2 J1 K1 L1 M5 NA O2 P1 T1 U1 V1 X1 Y1 Z1
```

Change settings if required.

Type Q and press Enter to go back into measurement mode.

If powering down the instrument and repowering and no change has been made to the baud rate (B command) then open a new terminal program at the units original baud rate setting (the default setting would be 9600 Bauds).

10.5. Status (error) codes

The Status code is sent as part of each wind measurement message.

Note: Status Codes 60 to 69 are only applicable to a unit with the heating option.

Code	Status	Condition
00	OK Heating set off	Valid data, sufficient samples in average period
60 (H2)	OK and heating enabled	Valid data, sufficient samples in average period
A	OK	NMEA data Acceptable
01	Axis 1 failed	Insufficient samples in average period on U axis
02	Axis 2 failed	Insufficient samples in average period on V axis
04	Axis 1 and 2 failed	Insufficient samples in average period on both axes
08	NVM error	NVM checksum failed, data could be uncalibrated.
09	ROM error	ROM checksum failed, data could be uncalibrated.
51	Measurement average building.	Data valid but warns that average period not reached when averaging used (non-heat enabled units only).
62 (H2)	No power to heating module	Valid data still output
63 (H2)	Hardware fault – e.g. Heater pcb faulty	Valid data still output.
65 (H2)	Warning – Heater Supply volts too high or pcb too hot.	Valid data still output.
V	NMEA data Void	Invalid data output
66 (H3)	OK and heating enabled	Valid data, sufficient samples in average period
67 (H3)	No power to heating module	Valid data still output.
68 (H3)	Hardware fault – e.g. Heater pcb faulty	Valid data still output.
69 (H3)	Warning – Heater Supply volts too high or pcb too hot.	Valid data still output.

10.6. Bench test

Data Tests

1. Couple the WindObserver 70/75 to the host system and power supply, using a known working test cable.
2. Check that the unit is correctly configured by going into Configuration mode and using [D3](#) See Section 8.4 *Checking the Configuration*.
3. Check for normal output data, and that the Status Code is OK – 00, 60, 66 or A (for NMEA format).
4. If the status code is other than these, refer to Section 9.5 Status (error) codes.
5. Use an office fan or similar to check that the unit is sensing wind, turning the unit to simulate changing wind direction and to check that both axes are functioning.
6. Note that this is a quick functional test. There are no calibration adjustments; the unit is designed NOT to require re-calibration within its lifetime.

Heater Tests (Heater Option (Only))

1. Connect the WindObserver Sensor and Heater connections to a 24v dc, 7A or greater supply.
2. Switch on the 24v dc supply and observe that the peak heater current drawn is greater than 4 amps.
3. Heating current will be taken for about 60 seconds, check that after this period each of the 4 sensor bullets is warm to touch.

Use of an Integrity Check Chamber (Optional Item)

The Integrity Check Chamber (ICC) is designed to:

1. Provide a zero wind environment to confirm the WindObserver zero calibration.
2. Identify any gross changes in the head geometry that would affect the performance.

The ICC has been designed to be used in an indoor still air environment with an ambient temperature between 17°C and 23°C. When conducting the test it is important that the ICC is assembled on to the WindObserver head and not touched or moved during the test.

This test is only valid if undertaken with an ICC purchased from Gill.

Note:- The Heater supply should be disconnected or turned off when using the ICC.

Zero Wind Check

Configure your PC to run HyperTerminal and assemble the ICC by inserting the reflector cases and the two halves of the ICC onto the WindObserver 70/75. The ICC must be retained using the strips provided. Then:

1. Ensure that the WindObserver 70/75 is set for Polar (M2) mode. For Factory default settings see section 8.4.
2. Enter Measurement Mode and Record/View data

In still air wind speed measurements should not exceed 0.03m/s. If wind speed exceeds 0.03m/s contact Gill Instruments.

Alignment Check

Ensure the ICC is assembled correctly on the WindObserver 70/75 and heating supply turned off. Using HyperTerminal, enter Configuration Mode as described in Section 8. Enter D6.

A typical report as shown below will be displayed.

```
D6
ALIGNMENT LIMITS: U=2424,2524
                  V=2434,2434
ALIGNMENT U:2474 *PASS*
ALIGNMENT V:2484 *PASS*
D6
```

If 'Refer to Manual' is shown check test temperature conditions are 17 to 23 deg C and tested under zero wind condition.

If there has been no significant changes to The WindObserver 70/75 head configuration then *PASS* will confirm correct operation.

Alterations to the head geometry can result in a *FAIL* or 'Insufficient Samples' message. If this occurs please contact Gill Instruments.

10.7. Returning units

If the unit has to be returned, it should be carefully packed in the original packaging and returned to your authorised Gill distributor, with a full description of the fault condition.

11. APPENDICES

11.1. Glossary & Abbreviations

Item	Meaning
CAL	Calibration
CR	Carriage Return
CRLF	Carriage Return Line Feed
CSV	Comma Separated Variable
ENG	Engineering
ESC	ESCAPE key on keyboard used to stop any process that is being executed
ETX	End of string character
FAC	Factory
fpm	Feet per minute
GND	GrouND
HEX	HEXadecimal
I/P	InPut
IP66	Protection Classification
KPH	Kilometres per Hour
LF	Line Feed
m/s	Metres per second
MAG	MAGNitude - scalar reference to wind speed
MAX	MAXimum
MPH	Miles per Hour
NEMA	National Electrical Manufacturers Association
NMEA 0183 (version 3)	National Marine Electronics Association standard for interfacing marine electronic navigational devices
No:	Number
NVM	Non-Volatile Memory
O/P	Output
PC	IBM compatible Personal Computer
PCB	Printed Circuit Board
POR	Power On Reset
ROM	Read Only Memory
RS232	Communications standard

Item	Meaning
------	---------

Item	Meaning
RS422	Communications standard
RS485	Communications standard
RTS	Request To Send
RWA	Road Weather Averaging
RX	Receive
RXD	Received Data
S/W	SoftWare
SOS	Speed Of Sound
SEC	SECond
STX	Start of string character
TERM	TERMinal
TX	Transmit
TXD	Transmitted Data
+VE	Positive
-VE	Negative
WRT	With Respect To

11.2. Guarantee

For terms of guarantee contact your supplier.

Warranty is void if the green security seal covering base nuts is damaged or broken, or the transducer caps have been damaged.

11.3. Principle of operation

The WindObserver 70/75 measures the times taken for an ultrasonic pulse of sound to travel from the North transducer to the South transducer, and compares it with the time for a pulse to travel from S to N transducer. Likewise times are compared between West and East, and E and W transducer.

If, for example, a North wind is blowing, then the time taken for the pulse to travel from N to S will be faster than from S to N, whereas the W to E, and E to W times will be the same. The wind speed and direction (and the speed of sound) can then be calculated from the differences in the times of flight on each axis. This calculation is independent of factors such as temperature.

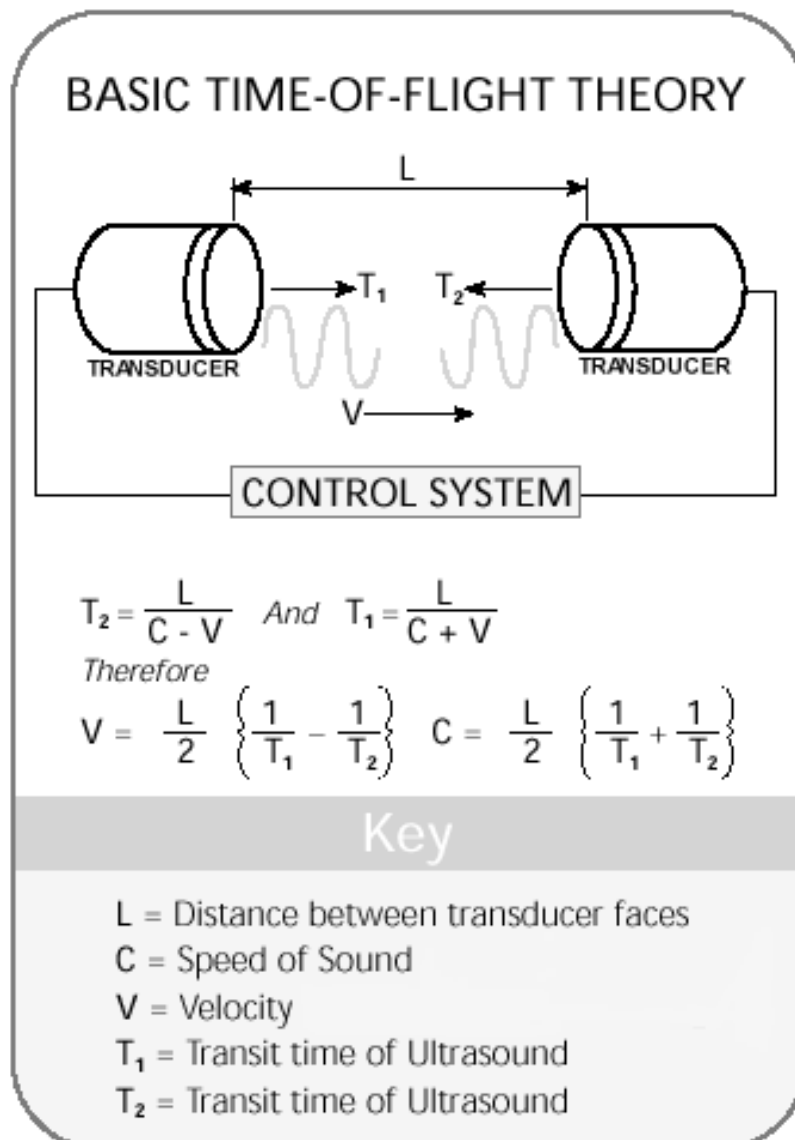

11.4. Electrical Conformity

EU Declaration of Conformity

We **Gill Instruments Limited**
Of **Saltmarsh Park**
67 Gosport Street
Lymington
SO41 9EG
England



In accordance with the following CE Directives:



Hereby declare under our sole responsibility that the following products have been designed and where appropriate, manufactured and tested in accordance with the applicable requirements of the following European harmonised standards and where applicable, IEC Standards:

1390 WindObserver Anemometer

EMC Emissions & Immunity	EN60945:2002 EN61326-1:2013
Restriction of Hazardous Substances	EN50581:2012

Signed by: 

Print Name: **R. McKay**
Position: **Product Manager**
Date of Issue: **14th February 2017**
Place of Issue: **Gill Instruments Ltd, Lymington**

Change Note: **9085**

Doc No: **1390-045**

Issue: **02**

Date: **14/02/2017**