

**multitek**

**M560**

# multitek



## POWERSIG

The M560 PowerSig is a complete 1 phase or 3 phase multifunction AC power transducer, providing up to 3 analogue outputs and the option of RS485 communication port. Most of the parameters measured by PowerSig can be assigned to the analogue outputs.

## PARAMETERS MEASURED

- \* Phase Voltage (V)
- \* Line Voltage (V)
- \* Phase Current (I)
- \* Frequency (Hz)
- \* Active Power per phase (W)
- \* System Active Power (W)
- \* Reactive Power per phase (VAr)
- \* System Reactive Power (VAr)
- \* Apparent Power per phase (VA)
- \* System Apparent Power (VA)
- \* Import Active Energy (W.h)
- \* Export Active Energy (W.h)
- \* Import Reactive Energy (VAr.h)
- \* Export Reactive Energy (VAr.h)
- \* Apparent Energy (VA.h)
- \* Ampere Energy (A.h)
- \* Power Factor per phase (P.F.)
- \* System Power Factor (P.F.)
- \* Amp Demand (Ad)
- \* Watt Demand (Wd)
- \* V A Demand (VAd)
- \* Maximum Amp Demand (Max Ad)
- \* Maximum Watt Demand Import (Max Wd)
- \* Maximum Watt Demand Export (Max Wd)
- \* Maximum VA Demand (Max VAd)
- \* Neutral Current

## ANALOGUE OUTPUTS

Up-to 3 fully isolated analogue outputs are available. Most of the parameters measured can be assigned to the outputs. Outputs can be either DC mA or DC volts.

If PowerSig is purchased without the option of RS485 the user must specify which parameter is required for each output when ordering.

## OPTIONS

### COMMUNICATION

PowerSig uses RS485 Modbus protocol.

This enables remote reading and programming of the PowerSig via a host computer.

The RS485 allows up to 32 PowerSigs to be connected in parallel, allowing them to be used with PC, PLC, RTU, Data loggers and Scada programs.

The PowerSig's communication port is auto-configurable meaning that when connected to an existing Modbus network it will automatically set Baud rate, Parity and Stop bits. A red LED is provided to indicate power is present, and the unit is communicating correctly.

### Programming.

The following can be programmed via the RS485 port: CT and VT ratios, assigning parameters to outputs, pulse duration, relay divisor.

### Software.

Set-up and monitoring software is available free from your Multitek distributor or visit the Multitek website [www.multitek-ltd.com](http://www.multitek-ltd.com)

## PULSED OUTPUT

An option of pulsed output via a relay is offered. The pulsed output can be assigned to W.h, Var.h (import or export), A.h or VA.h. Optionally the relay can also be used as a control relay.

## ORDERING INFORMATION

Information required	Example
Product Code	M560-AT9
Nominal input voltage	230 / 400V AC
Nominal input current	5A AC
System Frequency	50Hz
Auxiliary	230V
Output	3 x 4-20mA
Option	RS485 Modbus.

## GENERAL SPECIFICATION

### INPUT

<b>Rated Un</b>	Direct connected voltages between 57.8 and 600 V. Specify nominal.
<b>Range</b>	2-120% Un
<b>Overload</b>	1.5 x Un cont. 4 x Un for 1 sec
<b>Rated In</b>	1 or 5 amp
<b>Range</b>	0-120% In
<b>Burden</b>	0.5VA per phase Volts & Amps
<b>Overload</b>	4 x In continuous. 50 x In for 1sec
<b>Frequency</b>	50 / 60 Hz nominal range 45/65Hz

### ACCURACY

<b>Specified @ 23°C</b>	10%-Un 10%-In
<b>Parameters unless stated</b>	Class 0.3% to IEC 688
<b>Volts and Amps</b>	Class 0.25% to IEC 688
<b>Frequency</b>	Class 0.1Hz to IEC 688
<b>Power Factor</b>	Class 1.0% to IEC 688
<b>Active &amp; Reactive Energy</b>	1% of reading IEC1036

### INSULATION

<b>Test Voltage</b>	4 kV RMS 50 Hz for 1 min
	Inputs/Case/Auxiliary/Output
	3kV RS485 / Outputs
	1.5kV Relay
	1kV between Outputs.
<b>Impulse Test</b>	EMC 5kV transient complying with IEC 801 / EN 55020 HF
<b>Surge withstand</b>	IEC 801 / EN55020
	ANSI C37.90A
<b>Interference</b>	EHF 2.5 kV 1Mhz
	complying with IEC 255-4
<b>Protection Class</b>	Class II complying with IEC348

### APPLIED STANDARDS

<b>General</b>	IEC 688 BSEN60688, BS4889, IEC 359
<b>EMC</b>	Emissions BSEN50081/1
	Immunity BSEN50082/2
<b>Safety</b>	IEC 1010, BSEN601010

### AUXILIARY

<b>AC voltage</b>	115 or 230 or 277 volts (±15%)
<b>DC voltage</b>	12 / 24 / 48 / 110 / 125 volts (±15%)

### ENVIRONMENTAL

<b>Working Temperature</b>	0 to +60 deg C
<b>Storage Temperature</b>	-30 to +65 deg C
<b>Temperature Coefficient</b>	0.01% per deg C

# multitek®

## ANALOGUE OUTPUTS

<b>3 outputs</b>	Programmable to any 3 parameters (Apart from energy measurements)
<b>Rated value</b>	Specified @ 20mA
	0-1mA into <10 kOhm load
	0-5mA into <2 kOhm load
	0-10mA into <1 kOhm load
	0-20mA into <0.5 kOhm load
	4-20mA into <0.5 kOhm load
	0-10 volts > 1kOhm load
<b>Load influence</b>	<0.1%
<b>Ripple</b>	<0.5% peak-peak at full load
<b>Response time</b>	<400 msec for 0-99% at full load
<b>Overload</b>	<2 x rated value at full load
<b>No load voltage</b>	< 18 volts

### APPROVALS

UL, C-UL, CSA

### CASE DIMENSIONS

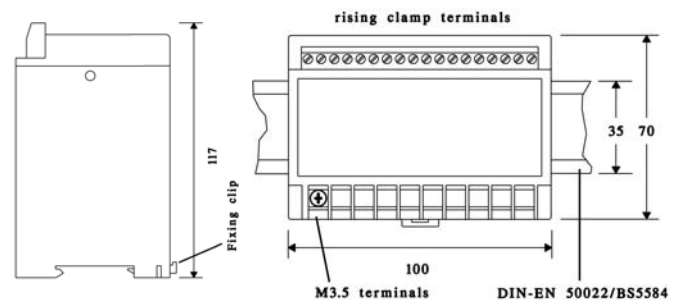

### CONNECTION DIAGRAMS

